

# Graffiti Identification System Using Low-Cost Sensors

Miguel García García<sup>1\*</sup>, Angélica González Arrieta<sup>1,2\*</sup>, Sara Rodríguez González<sup>1,2\*</sup>, Sergio Márquez-Sánchez<sup>2</sup>, Carlos Fernando Da Silva Ramos<sup>3</sup>

<sup>1</sup> Dept. of Computer Science and Automation, Faculty of Science, University of Salamanca, Plaza de los Caídos s/n, 37008, Salamanca (Spain)

<sup>2</sup> BISITE Research Group, University of Salamanca, Edificio I+D+i, Calle Espejo 2, Salamanca 37007, Salamanca (Spain)

<sup>3</sup> Institute of Engineering, Polytechnic of Porto, Rua Dr. António Bernardino de Almeida 431, 4200-072, Porto (Portugal)

\* Corresponding author. miguel@restnova.net (M. García García), angelica@usal.es (A. González Arrieta), srg@usal.es (S. Rodríguez González).

Received 28 April 2022 | Accepted 30 January 2023 | Early Access 8 May 2023



## ABSTRACT

This article introduces the possibility of studying graffiti using a colorimeter developed with Arduino hardware technology according to the Do It Yourself (DIY) philosophy. Through the obtained Red Green Blue (RGB) data it is intended to study and compare the information extracted from each of the graffiti present on different walls. The same color can be found in different parts of a single graffiti, but also in other graffiti that could a priori be of different authorship. Nevertheless, graffiti may be related, and it may be possible to group graffiti artists and "gangs" that work together. The methodology followed for the construction of the colorimeter and its real application in a practical case are described in four case studies. The case studies describe how graffiti were identified and recognized and they provide a comparison of the collected color samples. The results show the added value of the colorimeter in the graffiti recognition process, demonstrating its usefulness on a functional level. Finally, the contributions of this research are outlined, and an analysis is carried out of the changes to be made to the proposed method in the future, for improved graffiti color identification.

## KEYWORDS

Colorimeter, Crew, Graffiti, Image Color Analysis, Low-Cost Sensors, Tag.

DOI: 10.9781/ijimai.2023.05.001

## I. INTRODUCTION

THE identification and classification of graffiti is a discipline of interest, not only to authors belonging to this urban tribe or graffiti writers, but also to institutions interested in controlling and reducing the presence of this type of vandalism. There are different classification systems proposed from the very moment in which a graffiti is created [1] and stylistic or calligraphic systems are used in its identification [2]. Just as it is possible for an expert calligrapher to analyze signatures, it is also possible to classify graffiti by identifying its characteristics.

This study aims to assess the use of a low-cost TCS34725 color sensor and a colorimeter, to automate the identification of graffiti [3], assuming that this tool is capable of improving graffiti characterization accuracy, as this factor had not been taken into account when identifying it (from the state of the art, it could be verified that images may be analyzed using this colorimeter, however, their chromatic "reliability" had not been considered).

The function of a colorimeter is to accurately determine the color applied to a surface. There are different types of colors on the market,

depending on the intended use and the default color pattern in different numerical parameters (RGB, CMYK, etc.). The applications of this device include determining a color on a wall to produce another with the same characteristics or determining the ripening point of different fruits. Currently there are works which have used those devices, some in the field of health [4] and others in the analysis and interpretation of digital images [5], [6]. There are previous works on color analysis and the construction of low-cost sensors [7], graffiti documentation methods [8] and artificial vision [9]. Regarding the analysis of graffiti and paintings, there are studies regarding their chemical analysis [10], the prevention of graffiti [11] or the analysis of color in rock art [12]. In this case, it has been decided to build the colorimeter to understand the entire process and thus determine what needs to be taken into account for its improvement in the future.

The colorimeter is composed of a red, green and blue light-emitting diode (RGB LED) [13], a focusing lens, a 3D-printed cuvette holder, and a light-sensitive photodiode detector. The processing technology of the Arduino microcontroller has been used. This device simulates the response of the standard observer and can match most colors in the visible spectrum. Using an internal light source, the colorimeter illuminates the sample surface; As light reflects off the device, it

Please cite this article as:

M. García García, A. González Arrieta, S. Rodríguez González, S. Márquez-Sánchez, C. F. Da Silva Ramos, "Graffiti Identification System Using Low-Cost Sensors", International Journal of Interactive Multimedia and Artificial Intelligence, vol. 8, no. 6, pp. 51-60, 2024, <http://dx.doi.org/10.9781/ijimai.2023.05.001>

passes through three filters: red, green, and blue. These filters distill the values of the three stimuli (RGB) that match the way our eyes see color according to its intensity, as illustrated in Fig. 1 and Fig. 2 [14].



Fig. 1. RGB color code.

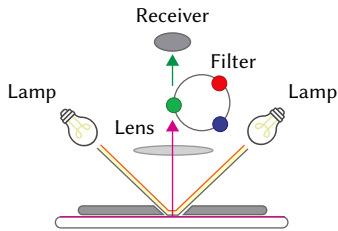

Fig. 2. Colorimeter operation.

Arduino is an open-source platform for the creation of electronics, based on free hardware and software. It is flexible and easy to use for creators and developers. This platform enables the creation of different types of “small computers” [15] on a single board, that can be put to different types of use by communities of creators, individual users and developers. As the hardware is free it offers a basis on which a person or company can create their own boards, which may be different from each other, but equally functional. Moreover, because the software is free, it offers the Arduino IDE platform (Integrated Development Environment) [16]; a programming environment with which anyone can create applications for Arduino boards [17], so that they can be given all kinds of utilities. Their code is made accessible to all, so that anyone can use it and modify it [18].

Therefore, Arduino is based on a board with a microcontroller as hardware [19], and a development environment called IDE, which is an open and free software that facilitates the use of electronics and microcontrollers in multidisciplinary projects [20].

On this platform, a colorimeter has been built using the TCS34725 digital color sensor [21], [22]. This is intended to obtain a sufficiently reliable data relationship based on the different color samples.

The research described in this article has been carried out with the aim of achieving the following objectives:

- Achieve the functionality of a colorimeter built with Arduino.
- Check that the data obtained with the colorimeter are reliable.
- Evaluate the colorimeter as a graffiti identification tool.

The rest of the article is structured as follows: Section II analyzes the previously proposed related methods and techniques for color identification. In Section III, the proposed system is described. In Section IV the experimental results are presented and finally, conclusions are drawn regarding the performance of the proposed system and future work is outlined in Section V.

## II. PRELIMINARIES

The colorimeter is a device with special sensitivity which enables it to detect different color ranges. For example, it is used to determine the ripening point of a fruit [23] or the color of a food according to the consumer’s tolerance level (studies with meat products [24] and dairy products [25]). It is also used to detect a color that needs to be reproduced in the automotive industry or in interior decoration [26]. In this specific case, the objective is to use it in the identification of graffiti from the obtained data by reading the colors through the sensor.

The TCS34725 (Fig. 3. Sensor TCS34725.) is a sensor that is capable of calculating the value of the different components that make up the color through Inter-Integrated Circuit (I2C) communication, the sensor sends the data on the level of red, green, blue light present in a color. The communications make it very easy to integrate it in any device controlled by a main control unit (MCU), as it comes with a development board for the implementation of integrated circuits.

This sensor’s features include RGB LED backlight control, light color temperature measurement, ambient light detection for screen backlight control, fluid and gas analysis, and verification and classification of the color of the products. For this reason, it can be found in televisions, smartphones, tablets, computers, monitors, printers, in medical devices, in signaling devices or in industrial automation.

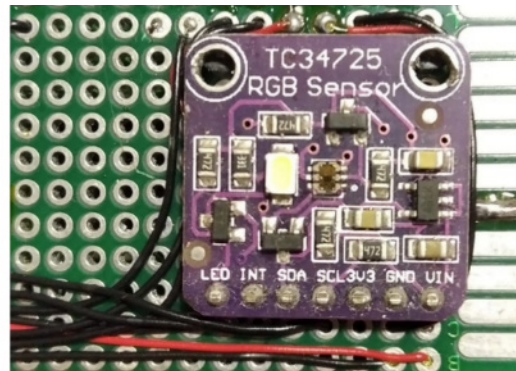

Fig. 3. Sensor TCS34725.

The operation of the TCS34725 [27] consists of an array of 3x4 reverse biased photodiodes which produce a small electric current when excited by light of a certain wavelength. In addition, they have an infrared filter (IR) to minimize the response to this range of the spectrum (Fig. 4. Representation of the photodiode array in the package. Response graph of photodiodes as a function of wavelength (TCS34725 Datasheet).

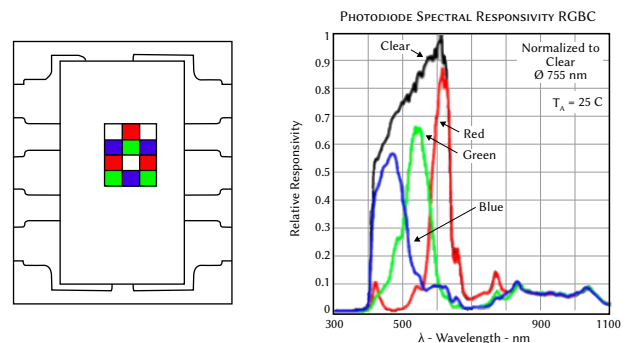

Fig. 4. Representation of the photodiode array in the package. Response graph of photodiodes as a function of wavelength (TCS34725 Datasheet).

The small current generated by the photodiode causes a change in its voltage when excitation occurs. The variation in voltage is measured with an Analog-Digital Converter (ADC) (Fig. 5. Sensor functional block diagram (TCS34725 Datasheet).

The ADC converters integrate the measurement of the photodiodes [28]. These measurements are transferred to the internal registers of the TCS34725 [29], which incorporate a double buffer to ensure data integrity. The state of the sensor and the energy is controlled by an internal state machine, which controls all the functions of the TCS34725 [30]. The sensor has a dynamic range of 3,800,000:1 with adjustable integration time and gain, making it suitable for use behind

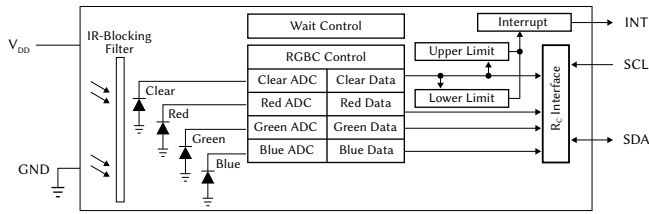

Fig. 5. Sensor functional block diagram (TCS34725 Datasheet).

tinted glass or fabric. The programmable interrupt pin allows for interruptions in the level of light when preset values are exceeded, thus reducing microprocessor overload. The TCS34725 sensor has a low power standby state to reduce average power consumption:

- Low consumption: 2.5 $\mu$ A in sleep mode.
- 65 $\mu$ A in standby mode, with programmable standby time from 2.4ms to 7 seconds.

Taking into account the existence of works in other fields [31] related to the identification of mural paintings [32] or the identification of graffiti on roads [33], we consider that the use of the colorimeter can be assessed in relation to different previously selected graffiti on a public street wall. The section that follows describes the construction of the colorimeter which has made it possible to capture colorimetric values related to the graffiti in question [34].

### III. GRAFFITI IDENTIFICATION SYSTEM

This section describes the developed system, both its functional and electronic description.

#### A. Functional Description

The system can be divided into the following functional steps (Fig. 7):

- Step 1. Selection of the area graffiti image collection. In this step, the area to be measured was selected, taking into account the graffiti image to be studied.
- Step 2. Image reading through RGB levels by the TCS34725 sensor. The TCS3472 Light-to-Digital Converter contains a 3x4 photodiode array consisting of red, green, blue, and clear (unfiltered) IR-cut filter-coated photodiodes. These determine the color when excited inversely with a certain wavelength, generating a small current that is transformed into a signal thanks to the use of four analog-digital converters integrated in the photodiodes, which simultaneously convert the amplified currents of the photodiodes into a 16-bit digital value. At the end of a conversion cycle, the results are transferred to the data registers and double buffering ensures data integrity. For internal timing control and low power wait state, a state machine is used.
- Step 3. Image processing by means of image fragmentation. The RGBC engine (Fig. 6. RGBC operation.) contains the gain control and four analog-digital converters integrated in the photodiodes. The integration of all four channels occurs simultaneously, and once the conversion cycle is complete, the results are transferred to the color data registers, doing what is called a channel count. An important issue to consider is the integration time, as it affects both the resolution and sensitivity of the RGBC readout. The communication of the TCS3472 data is carried out through a transfer of up to 400 kHz, two-wire of the I2C standard, which facilitates direct connection with microcontrollers and embedded processors.
- Step 4. Comparison of values with the cathode and corresponding LED lighting. Data reads are double buffered to ensure that no

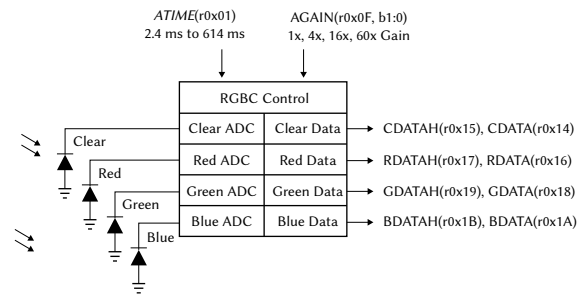

Fig. 6. RGBC operation.

invalid data is read during the transfer. The red, green, blue and clear (unfiltered) read data is stored as 16-bit values. To ensure that this data has been read correctly, a two-byte I2C read is performed, with single word bit reading set by the command register. If both values are equal, the transfer is verified, and the device automatically passes to the next state according to the configured state machine.

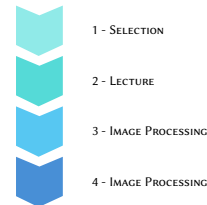

Fig. 7. Functional description.

#### B. Sensor Description

Shooting is affected by different values. In the case of the TCS34725 sensor, it is expected to be able to obtain reliable color samples for the comparison of some graffiti with others, making it possible to establish a link between them in terms of color.

The purpose of the device is to measure color and display the levels of each RGB component on a liquid crystal display (LCD). Additionally, an RGB LED has been added to display the measured color. The scheme of the device is shown in Fig. 8.

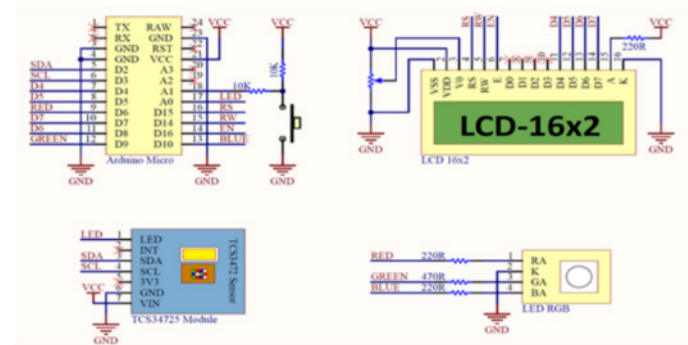

Fig. 8. Schematic of the electronic assembly.

The main controller is an Arduino Micro development board [35]. The device is powered by the micro-USB connector integrated in the Arduino board. Through the VCC pin of the Arduino, 5V power is provided to the rest of the components of the circuit.

Connected to pin A1 is a push button. Pressing it initiates the color reading. To do this, the LED integrated in the TCS34725 module, which is connected to pin A0 of the Arduino, lights up. The connection of the TCS34725 module is simple, it is done through the I2C of the Arduino, pin D2 for the data line and D3 for the clock signal.

Once the reading was done, the different values for RGB were shown on the LCD display. This is a 2-line alphanumeric display with 16 characters per line. The connection to the Arduino was configured for 4-bit parallel communication. Also, on the V0 pin of the display a potentiometer has been added to manually adjust the contrast of the LCD.

Lastly, with the measured RGB values, the outputs of the Arduino are adjusted so that the RGB LED is lit in the same color as has been measured. To do this, a line for the RGB component was used; D6 for red, D9 for green and D10 for blue. The RGB LED is common cathode.

The entire circuit has been mounted on a perforated plate as shown in Fig. 9.

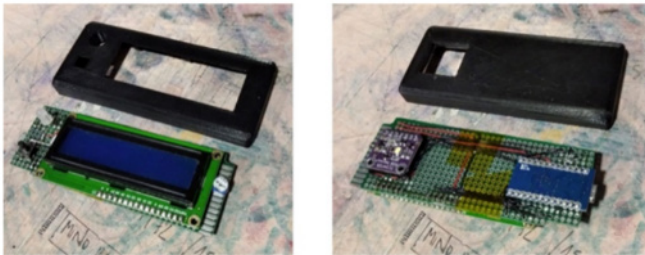

Fig. 9. Colorimeter assembly.

#### IV. EXPERIMENTAL RESULTS

In the experimental results section, two subsections are presented. The first one presents a preliminary investigation which has been carried out on the abandoned walls located in the vicinity of the Faculty of Fine Arts of the University of Salamanca and presents a measurement and color acquisition experiment using the colorimeter built in the current study. The second subsection presents three case studies demonstrating how the use of this type of methodology is suitable for the automatic characterization and authorship analysis of graffiti.

##### A. Color Acquisition Preliminary Experiment

The present investigation has been carried out on derelict walls located in the vicinity of the Faculty of Fine Arts of the University of Salamanca, in the vicinity of the city of Salamanca but far enough to house a considerable number of graffiti and tags or signatures (Fig. 10 and Fig. 11).

At first, the photographic documentation of the graffiti to be studied was carried out, as well as its measurement. Following the documentation of the graffiti to be studied, those that had similar colors were chosen for the purposes of this research. Then, the digital color taking process began, using the color selection platform “Adobe Color” [36] and the colorimeter [37], providing the data to obtain the color codes.



Fig. 10. Graffiti wall. Case study. (Redmi Note 8 Pro, Xiaomi f/1.89, 1/653, ISO100 5.3mm, without Flash).

Three graffiti (Table I) have been analyzed to carry out the preliminary investigation. These are placed continuously and, apparently, use the same colors in their execution. These colors are white/silver, Prussian blue, Ultramarine blue, black and red.



Fig. 11. Lateral view graffiti case study. (Redmi Note 8 Pro, Xiaomi f/1.89, 1/325, ISO102, 5.43mm, without Flash).

TABLE I. GRAFFITI TO STUDY

GRAFFITI 1	WAVE	183 x 420 cm.
GRAFFITI 2	BAPOR	180 x 430 cm.
GRAFFITI 3	DONK	180 x 425 cm.

We started with the premise that the colorimeter, supported by a TCS34725 sensor, would obtain reliable values. In addition to taking several measurements of the same-colored surface, a color chart (CHROME GUIDE 1650 colors by Valentine) had initially been used as a reference. By taking this step, we intended to make the sampling through the sensor more reliable and thus ensure that the sampling is in a correct RGB measurement range.

Firstly, digital images of the graffiti were taken, and their colors were obtained through the “Adobe Colors” platform, obtaining the results shown in Fig. 12, Fig. 13, Fig. 14, Fig. 15, Fig. 16, Fig. 17 and Fig. 18.



Fig. 12. Processing and comparison of the different parts of graffiti 2 (BAPOR) with the color sensor (Redmi Note 8 Pro, Xiaomi f/1.89, 1/415, ISO100, 5.43mm, without Flash).

Subsequently, the colors were taken with the colorimeter and compared with the color chart. With these two tools, we focused on identifying the different types of blue in both pieces of graffiti for comparison.



Fig. 13. Different parts of graffiti 3 (DONK). Processing and comparison with the color sensor (Redmi Note 8 Pro, Xiaomi f/1.89, 1/360, ISO100, 5.43mm, without Flash).

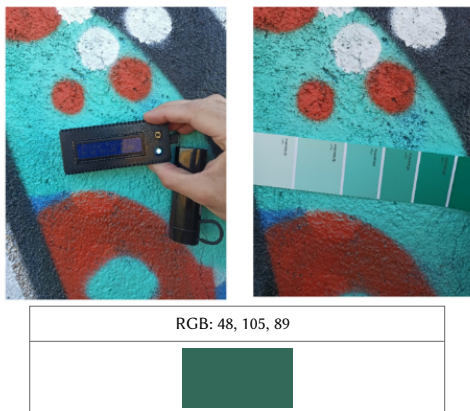

Fig. 14. Comparative study of the data obtained with the sensor and the color chart (graffiti 3). (Redmi Note 8 Pro, Xiaomi f/1.89, 1/100, ISO118, 5.43mm, without Flash) (Redmi Note 8 Pro, Xiaomi f/1.89, 1/123, ISO100, 5.43mm, without Flash).

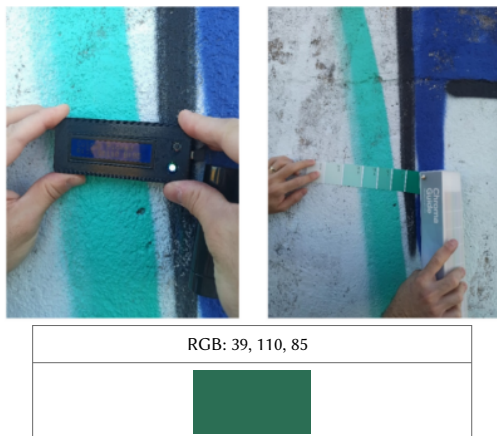

Fig. 15. Comparative study of the data obtained with the sensor and the color chart (graffiti 1) (Redmi Note 8 Pro, Xiaomi f/1.89, 1/100, ISO120, 5.43mm, without Flash) (Redmi Note 8 Pro, Xiaomi f/1.89, 1/141, ISO100, 5.43mm, without Flash).

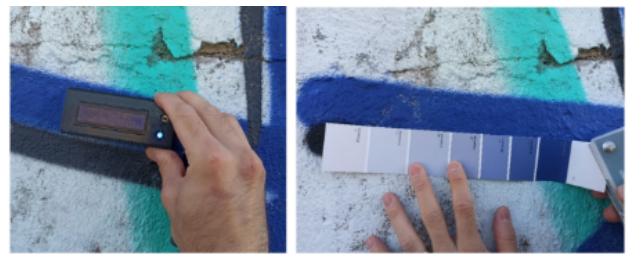

Fig. 16. Comparative study of the data obtained with the sensor and the color chart (graffiti 1) (Redmi Note 8 Pro, Xiaomi f/1.89, 1/168, ISO100, 5.43mm, without Flash) (Redmi Note 8 Pro, Xiaomi f/1.89, 1/162, ISO100, 5.43mm, without Flash).



Fig. 17. Comparative study of the data obtained with the sensor and the color chart (graffiti 1) (Redmi Note 8 Pro, Xiaomi f/1.89, 1/168, ISO100, 5.43mm, without Flash) (Redmi Note 8 Pro, Xiaomi f/1.89, 1/162, ISO100, 5.43mm, without Flash).



Fig. 18. Comparative study of the data obtained with the sensor and the color chart (graffiti 2) (Redmi Note 8 Pro, Xiaomi f/1.89, 1/100, ISO163, 5.43mm, without Flash) (Redmi Note 8 Pro, Xiaomi f/1.89, 1/100, ISO179, 5.43mm, without Flash) (Redmi Note 8 Pro, Xiaomi f/1.89, 1/100, ISO141, 5.43mm, without Flash).

In this case, the advantages of using the colorimeter included:

- Simple design and easy handling and mobility (portable).
- Reduced cost of materials.
- Electric charge easy to manage with powerbank-USB.
- Obtaining RGB color data is independent of ambient light.

There are some drawbacks related to colorimeters [9], such as a limited measurement area (2 cm x 2 cm), the restriction that the sample must have a uniform appearance, the location of the sample and the number of readings is significant for representative color evaluation and reflectance properties may be cause of disturbances in color detections.

**B. Using Colorimeter to Identify Graffiti Authorship**

Once the preliminary study of the colorimeter has been carried out, three case studies are presented in this results subsection. It is demonstrated how the use of this type of methodology is adequate for the automatic characterization and analysis of graffiti authorship. The following case studies have been carried out:

1. A case study on graffiti artists from the same or different crews. The crew, in its most general sense, speaks of a group made up of people who generally work under the direction of the same leader. The first case study presents a study of the graffiti crews: WAVE, BAPOR and DONK, demonstrating whether or not they belong to the same crew.
2. A case study on the same graffiti artist who changes tag: MEAS and 12345. It is common for a graffiti artist to change their identity and sign with a different name. On many occasions this is done with the intention of avoiding criminal consequences. In the second case study, such a scenario is identified by using the presented colorimeter methodology.
3. A case study on the same graffiti artist who has used the same color to paint in different locations: two OVIS graffiti. The third case study presents the identification of authorship of the same author through the described technique.

After having carried out the first study presented in the first results subsection, several changes in the approach were proposed, taking into account the following aspects:

- Different locations around the city of Salamanca.
- In each case, 10 samples of the same color are taken with the colorimeter.
- The format of the obtained numerical data has been maintained, using statistical analysis.

A coincidence study has been carried out in which different colors from different graffiti have been selected. In those cases in which the colorimeter values coincided, it could be assumed that they had been made by the same crew or by the same author.

**Case Study 1: WAVE, BAPOR and DONK Graffiti in the City of Salamanca.**

The studies have been carried out selecting different colors and the result has been similar in all of them. In this case, the presented color was light blue and it was used to assess whether there was a colorimetric relationship between the three graffiti.

Fig. 19 shows the RGB values obtained by the colorimeter on the Y axis and the sample taken over time on the X axis. In addition, the integer values are shown in the table below and the error bars containing the standard deviation, indicating how spread out the data are around the sample mean. After comparing the values (RGB) obtained from the colorimeter we can conclude that there is a very close link between WAVE and BAPOR, but these same values are slightly further apart in the case of DONK. These results have been confronted with police sources and it has been confirmed that WAVE and BAPOR are from the same crew and not related to DONK.

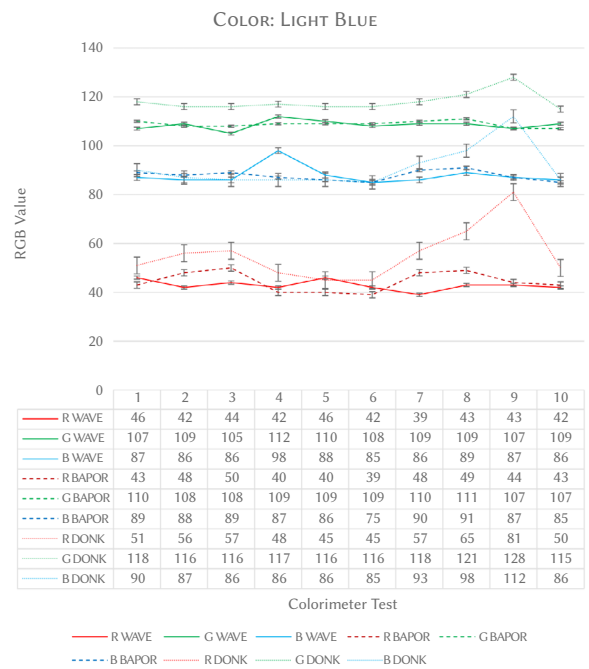

Fig. 19. Comparative table of RGB values taken as a sample, the “light blue” color in the graffiti WAVE, BAPOR and DONK.

**Case Study 2: Graffiti “12345” Vs. Graffiti “MEAS” in the City of Salamanca**

Case study 2 is a comparative experiment of two apparently different graffiti taking into account the descriptive color, which was different from the most common colors, namely, black, silver or white. In this case, the studied color is yellow to assess whether there is a colorimetric relationship between the two. Fig. 20 and Fig. 21 show the analyzed graffiti and Fig. 22, the values obtained in the study in the same way as in the first case.



Fig. 20. Graffiti 12345.



Fig. 21. Graffiti MEAS.

The premise to be taken into account is caused by police information that links the same person as the author of both styles (12345 would be the evolution of the MEAS tag) (12345 which is “12” like the “M”, “3” the “E”, “4” the “A” and “5 the “S”).

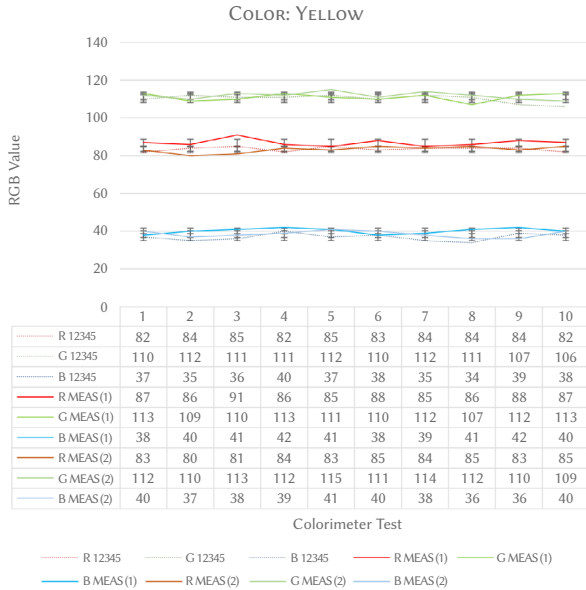

Fig. 22. Comparative table of RGB values taking as a sample the color “yellow” in graffiti 12345 and MEAS.

In this case, the initial premise is fulfilled by which the yellow color compared between both graffiti have the same colorimetric values. The conclusion according to the data obtained and the interpretation from this comparison is that it is the same author, or the same type of color has been used to paint with the same type of yellow in both cases.

### Case Study 3: Two “OVIS” Graffiti in Two Different Locations in the City of Salamanca.

This comparative study shows two apparently equal graffiti considering that they share the same descriptive color and that it is different from the most common colors, namely, black, silver or white. In this case, the color being studied was light blue and the purpose of the study was to assess whether there is a colorimetric relationship between the two cases. Fig. 23 and Fig. 24 show the studied graffiti and Fig. 25 the results obtained. The premise in this case is to verify that the same author uses the same color in different pieces.



Fig. 23. Graffiti OVIS (1).



Fig. 24. Graffiti OVIS (2).

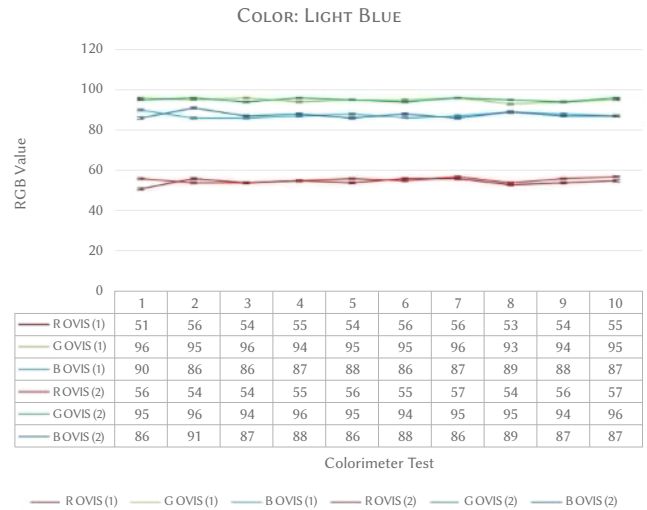

Fig. 25. Comparative table of RGB values taking as a sample the color “light blue” in two OVIS graffiti.

In this case, the initial premise has been fulfilled by which the light blue color compared in these graffiti has the same colorimetric values.

According to the obtained data and the interpretation of this comparison, the conclusion is that it is the same author, or the same type of color has been used to paint the light blue color in both cases.

## V. CONCLUSIONS

### A. Functionality and Reliability of the Colorimeter

From the experiments carried out using the colorimeter, we obtain sufficient reliability to consider it as a suitable identification tool for this use (Fig. 26). To ensure a correct methodology, several samples were taken and compared with a color chart, which is a calibration method carried out prior to the experiments.

From these color shots it has been possible to observe that the colorimeter is a reliable tool. The colorimeter has provided certain “logical” values despite taking samples on a rough surface (wall), where the color saturation is different depending on the area and where the use of different materials could affect the glossiness of the surface. The obtained values have moreover been compared with the reference value of the color chart and small variations were considered normal as the measurements had not been taken in a controlled environment.

When it comes to capturing different shades of the same color, the colorimeter has performed correctly, as shown in the previous images. However, for lighter colors, such as sky blue, despite the fact that the device’s small bulb emits light of a similar color, when passing the

numerical data from the colorimeter to an RGB reader, the obtained information was considered to be within the initial premise.













COLORIMETER	ADOBE DETECTION TOOL	COLOUR CARD
RGB: 48, 105, 89	RGB: 115, 217, 207	RGB: 143, 208, 189
		
COLORIMETER	ADOBE DETECTION TOOL	COLOUR CARD
RGB: 39, 110, 85	RGB: 85, 217, 204	RGB: 143, 208, 189
		
COLORIMETER	ADOBE DETECTION TOOL	COLOUR CARD
RGB: 30, 71, 136	RGB: 75, 98, 148	RGB: 65, 97, 144
		
COLORIMETER	ADOBE DETECTION TOOL	COLOUR CARD
RGB: 35, 74, 172	RGB: 30, 49, 108	RGB: 58, 95, 127
		

Fig. 26. Comparative table of the obtained color data.

Both the roughness of the wall, as well as the superimposition of some graffiti over others led to color differences in every centimeter of the graffiti as the wall had not been prepared in advance to carry out this type of graffiti. Even so, the colorimeter emits very similar results of the same color, regardless of the part of the wall in which we are and its state of conservation.

The use of the colorimeter has been validated as the data obtained for the same color on the same graffiti are within a range of stable values and this has made it possible to compare the same colors among different graffiti, with the aim of determining if they had the same colorimetric value.

### B. The Colorimeter as a Tool For Identifying the Author of the Graffiti

As we have seen, through the colorimeter we find great similarities between the colors used in different graffiti. This leads us to raise the possibility that these graffiti have been done at the same time by a crew. Although we apparently think of different authors, it is possible to assume that the same author would have done both graffiti or that different authors (different graphical symbols) would use the same color spray to make their pieces independently, since in this case they are also arranged in different ways in a correlative manner.

In the first place, they could be two different authors -because that is what the graphical symbols point to however, they have used the same colors to create visual unity. Particularity that could be motivated by the fact that both belong to the same group. It should be noted that, without prior knowledge, as a result of the investigation, the colorimeter data led us to the conclusion that WAVE and BAPOR had similar image color values and experts confirmed that they were from the same Crew, which is one of the cases clarified by the police.

Secondly, the similarity in the use of color may be indicating that it is the same artist who has changed his style over time but has decided to keep his color palette. The contribution of this work is of great value in this sense when the same graffiti artist uses tags that do not share

the same type as in the case study MEAS\_12345. Graffiti involves a creation process in which drawings are made in sketchbooks or blackbooks [38] where the author practices the graphical symbols that they are going to use in their graffiti. It would be possible to think of the same author who, through this process, was capable of imitating or plagiarizing the signature of another author with the interest of "bombing" an area with graffiti of different authorship. Through the coincidences established in this study, we could think of it as a possibility for this case.

In conclusion, this work arises from the collaboration with a group of police experts in the field, who emphasize that the colorimeter study is a contribution to graphic analysis in the same way that the discrimination of inks followed in Graphics can be. The analysis of inks used in graphics is currently a highly valuable test in the courts and its aim is to verify whether two parts of the same document were written with the same pen or a different one, as well as whether two documents were written with the same writing tool. Therefore, the research presented here can provide, either by itself or by the combination of colors, an added feature to the graphic analysis in the attribution of the authorship of a specific graffiti tag or the participation in a group action of the belonging crew.

### C. Future Lines of Work

Based on the results of this research, future studies will compare different surfaces or supports, and different materials used in the elaboration of graffiti. A comparative study could also be carried out to contrast the performance of this proposal with other capture systems [39]. Other types of sensors could be applied, such as the spectrophotometer which can also be used in the industry to identify colors reliably through the amount of light absorbed by a sample, measuring the full color spectrum [40].

A future study that would further validate the premises set forth in this article would involve taking color samples and analyzing them chemically (gas spectro-photogrammetry) and thus obtain more precise data. Implemented within an identification, authorship, graffiti software would be a valuable step as it would be an additional variable to store in the database for pattern analysis using artificial intelligence [41].

Another possible investigation is the study of external values that influence image processing [42]. In this way, the data obtained with a colorimeter can be controlled and equated to that of a digital image.

### ACKNOWLEDGMENTS

This work has been supported by the project "XAI - XAI - Sistemas Inteligentes Auto Explicativos creados con Módulos de Mezcla de Expertos", ID SA082P20, financed by Junta Castilla y León, Consejería de Educación, and FEDER funds.

### REFERENCES

- [1] F.J.A. Sanchis, "El postgraffiti, su escenario y sus raíces: graffiti, punk, skate y contrapublicidad", 2010, Doctoral Thesis.
- [2] C. Castleman, "Getting Up/Hacerse Ver: El graffiti metropolitano en Nueva York", CAPITAN SWING S.L, 2012.
- [3] H. B. L. Chi, D.N.N. Khanh, N.T.T. Vy, P.X. Hanh, T.N. Vu, H.T. Lam, N.T.K.P.L.Q. Hoang, "Development of a low-cost colorimeter and its application for determination of environmental pollutants", *Spectrochimica Acta Part A: Molecular and Biomolecular Spectroscopy*, vol. 249, 2021, doi: 10.1016/j.saa.2020.119212.
- [4] A.W. Muhamada, A.A. Mohammed, "Review on recent Computer Vision Methods for Human Action Recognition", *ADCAIJ: Advances in Distributed Computing and Artificial Intelligence Journal*, vol. 10, no. 4, pp. 361-379, 2022, doi: 10.14201/ADCAIJ2021104361379.
- [5] B.P. Sharma and R.K. Purwar, "Ensemble Boosted Tree based Mammogram



- image classification using Texture features and extracted smart features of Deep Neural Network”, *ADCAIJ: Advances in Distributed Computing and Artificial Intelligence Journal*, vol. 10, no. 4, pp. 419-434, 2022, doi: 10.14201/ADCAIJ2021104419434.
- [6] V.P. Mishra, “Texture Analysis using wavelet Transform”, *ADCAIJ: Advances in Distributed Computing and Artificial Intelligence Journal*, vol. 10, no. 1, pp. 5-13, 2020, doi: 10.14201/ADCAIJ2021101513.
- [7] P.K. Patnaik, P. Mahapatra, D. Biswal, S.K. Nayak, S. Kumar, B. Champaty, K. Pal, “Development of a low-cost color sensor for biomedical applications”, *Woodhead Publishing Series in Electronic and Optical Materials*, pp. 15-29, 2019, doi: 10.1016/B978-0-08-102420-1.00002-9.
- [8] R. Valente, L. Barazzetti, “Methods for Ancient Wall Graffiti Documentation: Overview and Applications”, *Journal of Archaeological Science: Reports*. Vol. 34, Part A, 2020, doi: 10.1016/j.jasrep.2020.102616.
- [9] D. Wu, D.W. Sun, “Colour measurements by computer vision for food quality control - A review”, *Trends in Food Science & Technology*, vol. 29, no. 1, pp. 5-20, 2013, doi: 10.1016/j.tifs.2012.08.004.
- [10] G. Pellisa, M. Bertasaa, C. Riccib, A. Scarcellab, P. Croverib, T. Polia, D. Scalaronea, “A multi-analytical approach for precise identification of alkyd spray paints and for a better understanding of their ageing behaviour in graffiti and urban artworks”, *Journal of Analytical and Applied Pyrolysis*, vol. 165, 2022, doi: 10.1016/j.jaap.2022.105576.
- [11] H. Teng, A. Puli, M. Karakouzian, X. Xu, “Identification of Graffiti Countermeasures for Highway Facilities”, *Procedia - Social and Behavioral Sciences*, vol. 43, pp. 681-691, 2012, doi: 10.1016/j.sbspro.2012.04.142.
- [12] J.F. Ruiza, J. Pereirab, “The colours of rock art. Analysis of colour recording and communication systems in rock art research”, *Journal of Archaeological Science*, vol. 50, pp. 338-349, 2014, doi: 10.1016/j.jas.2014.06.023.
- [13] L. Llamas, “Medir valores RGB con Arduino y sensor de color TCS34725”, 2018, enero, [Online]. <https://www.luisllamas.es/arduino-sensor-color-rgb-tcs34725/>
- [14] CÓDIGOS DE COLOR HTML, 2021, [Online]. <https://htmlcolorcodes.com/es/selector-de-color/>
- [15] ALLDATASHEET, Electronic Components Datasheet Search, 2022, [Online]. <https://pdf1.alldatasheet.com/datasheet-pdf/view/894928/AMSCO/TCS34725.html>
- [16] Y.A. Badamasi, “The working principle of an Arduino”, in 11 th International Conference on Electronics, *Computer and Computation (IECCO)*, 2014, doi: 10.1109/ICECCO.2014.6997578.
- [17] J.C.S. Allende, J.H. Herranz, “Una mirada al mundo arduino”, *Revista de Ciencia, tecnología y medio ambiente*, vol. 13, p. 28, 2015.
- [18] L. Llamas, “Medir el color con Arduino y el colorímetro TCS3200”, 2016, [Online]. <https://www.luisllamas.es/medir-color-arduino-colorimetro-tcs3200/>
- [19] P.J.P. Fernández, “Diseño y construcción de un colorímetro de tres canales. Aplicación al estudio experimental de modelos de visión del color”, 2004, Doctoral Thesis.
- [20] P.D. Puiui, “Color Sensors and Their Applications” *Optical Nano- and Microsystems for Bioanalytics, Springer Series on Chemical Sensors and Biosensors*, vol. 10, p. 43, 2012, doi: 10.1007/978-3-642-25498-7\_1.
- [21] H. Torres, “HETPRO”, 2017, [Online]. <https://hetpro-store.com/TUTORIALES/sensor-de-color-tcs3200-con-arduino/>
- [22] BRICO GEEK, “Cómo construir un selector de color con Arduino”, 2020, enero, [Online]. <https://blog.bricogeek.com/noticias/arduino/como-construir-un-selector-de-color-con-arduino/>
- [23] AQ INSTRUMENTS, “Aquateknica”, 2018, [Online]. <https://www.aquateknica.com/que-es-un-colorimetro-como-funciona-y-para-que-sirve/>
- [24] A. Dahl, K. Jensen, J.M. Carstensen, K.C. Camilla H. Trinderup, “Comparison of a multispectral vision system and a colorimeter for the assessment of meat color.” *Meat science*, vol. 102, p. 7, 2015, doi: 10.1016/j.meatsci.2014.11.012.
- [25] V. Tomovic, I. Djekic, J. Miocinovic, B.G. Solowiej, J.M. Lorenzo, F. J. Barba, I. Tomasevic. B. Milovanovic, “Colour assessment of milk and milk products using computer vision system and colorimeter”, *International Dairy Journal*, vol. 120, 2021, doi: 10.1016/j.idairyj.2021.105084.
- [26] J. A. Coronado Martín, “El color, mediciones y aplicaciones.: Universidad Técnica del Norte”, 2020.
- [27] K. Minolta, “Sensing Konica Minolta”, 2018, [Online]. <https://sensing.konicaminolta.us/mx/blog/colorimetros-vs-espectrofotometros/>
- [28] R. Stojanovic, D. Karadagic, “An optical sensing approach based on light emitting diodes”, *Journal of Physics: Conference Series*, vol. 76, p. 7, 2007, doi: 10.1088/1742-6596/76/1/012054.
- [29] Instructables Circuit, 2022, [Online]. <https://www.instructables.com/Color-Sensor-1/>
- [30] Y. Shen, K. Yang, Ch. Lee, Ch. W. Neal, N. Xiong, “Color sensors and their applications based on real-time color image segmentation for cyber physical system”, *EURASIP Journal on Image*, no. 23, p. 16, 2018.
- [31] P. Luque, M.J. Fez, M.D. Capilla, “Colorímetro Colorlab: un colorímetro triestímulo para aplicaciones docentes”, *Sociedad Española de Óptica*, Ed. Valencia, España, 2010.
- [32] Ch. Ruiz López, T. Hoyer, A. Rebentisch, A.M. Roesch, K. Herkert, N. Huber, H. Floss, F. Juan, “Tool mark analyses for the identification of palaeolithic art and modern graffiti. The case of Grottes d’Agneux in Rully (Saône-et-Loire, France)” *Digital Applications in Archaeology and Cultural Heritage*, vol. 14, 2019, doi: 10.1016/j.daach.2019.e00107.
- [33] I. Flores-Colen, J. de Brito, A. Dionisio, A. Moura, “Study of the cleaning effectiveness of limestone and lime-based mortar substrates protected with anti-graffiti products”, *Journal of Cultural Heritage*, vol. 24, p. 14, 2017, doi: 10.1016/j.culher.2016.04.004.
- [34] K. Kurata, “Open-source colorimeter assembled from laser-cut plates and plug-in circuits”, *HardwareX*, vol. 9, p. 13, 2021, doi: 10.1016/j.ohx.2020.e00161.
- [35] Instructables Circuits, 2022, [Online]. <https://www.instructables.com/Arduino-Color-Detection/>
- [36] ADOBE COLOUR. 2021. [Online]. <https://color.adobe.com/es/create/color-wheel>
- [37] X-RITE Pantone, 2022, [Online]. <https://www.xrite.com/blog/colorimeter-vs-spectrophotometer>
- [38] F. Figueroa, “El “graffiti movement” en Vallecas historia, estética y sociología de una subcultura urbana (1980-1996)”, 2003, Doctoral Thesis.
- [39] S. Westland, “Imagen digital. Apuntes sobre diseño gráfico”, 2001, [Online]. [http://www.gusgsm.com/como\\_funciona\\_un\\_espectrofotometro\\_de\\_reflectancia](http://www.gusgsm.com/como_funciona_un_espectrofotometro_de_reflectancia)
- [40] AQ instruments. aqinstruments, 2015, [Online]. <https://aqinstruments.wordpress.com/2015/10/08/colorimetros-y-espectrofotometros-comparacion-caracteristicas-funcionalidades-medicion-color/>
- [41] A.I. González, A.G. Arrieta, D. López-Sánchez. “Sistema inteligente en torno al mundo del graffiti”, 2020, *Avances en Informática y Automática. Decimocuarto workshop*.
- [42] V. Rajinikanth, S. Kadry, R. González-Crespo, E. Verdú, “A Study on RGB Image Multi-Thresholding using Kapur/Tsallis Entropy and Moth-Flame Algorithm”, *International Journal of Interactive Multimedia and Artificial Intelligence*, vol. 7, no. 2, pp. 163-171, 2021, <https://doi.org/10.9781/ijimai.2021.11.008>.



Miguel García García

Miguel García García is Technical Engineer from the University of Salamanca. Later he began his specialization in the artistic discipline: he has a degree in Fine Arts (University of Salamanca), a Diploma in the Conservation and Restoration of Cultural Assets (specializing in Painting), a Graduate Degree in Conservation and Restoration of Cultural Assets (specializing in Graphic Documents), a Degree in Art History (National University of Distance Education), Master’s Degree in Digital Animation (University of Salamanca), Master’s Degree in Sacred Art (Pontifical University of Salamanca). He is currently a doctoral student, making it compatible with his business project (since 2015), restNOVA SOLUCIONES ARTÍSTICAS, dedicated to the Conservation and Restoration of Cultural Heritage.



Angélica González Arrieta

Angélica González Arrieta holds a PhD in Computer Science from the University of Salamanca and is College professor. She is also a member of the renowned research group BISITE (Bioinformatics, Intelligent Systems and Educational Technology), which was created in 2000. In 2021, the University of Salamanca awarded her the “Gloria Vegué” award for excellence in teaching. Her

main line of research is the application of artificial intelligence in different fields: education, biometric identification, artificial vision, and data analysis. Regarding the publication and dissemination of results, the highlight is the set of 24 publications in international journals, of which 13 stand out with an impact factor, according to the JCR index (10 Q1, 3 Q2). Likewise, she has more than 50 publications in books and international congresses, some of them included in the CORE, SCL, etc. ranking. She collaborates on research issues with different companies in the private sector and also with public institutions such as the Ministry of the Interior. She has participated in multiple European (5), national (15) and regional (8) research projects. She has been the Principal Investigator of 12 teaching innovation projects. He has been awarded official recognition for two research periods of six years each.



Sara Rodríguez González

Sara Rodríguez is Associate Professor in the Department of Computer Science and Automation at the University of Salamanca. Her area of research is well-defined and focuses on the integration and use of multi-agent systems within the field of artificial intelligence; she formalized this line of research in her doctoral thesis in which an adaptive model for virtual organizations of agents was developed.

Research activity can be considered the strong point of her curriculum, as shown by the 43 articles published in prestigious international journals and included in the Journal Citation Reports and her participation as a member of the scientific committee and speaker at international conferences. Her participation in numerous research projects over the years, including 5 international projects, demonstrates the transfer capacity and research quality endorsed by both companies and institutions. She has currently been awarded 2 six-year research periods and one six-year transfer period by the CNEAI. Her H index in Google Scholar is 39 with more than 4000 citations of her articles. Currently, she continues with her teaching and research activity within the GIR BISITE and as a member of the IoT Digital Innovation Hub of the USAL. Moreover, she continually progresses on the lines of Artificial Intelligence and Computer Science within the Department of Informatics and Automation of the USAL.

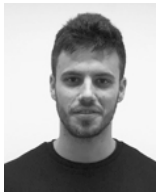

Sergio Márquez Sánchez

Sergio Márquez obtained the title of Industrial Engineer in 2017, from the University of Salamanca. At that same University he obtained his degree in Technical Engineering specializing in Mechanics (2014). In addition, he has a master's degree in Finite Element Design, Drafting, and Analysis with Autodesk Inventor, SolidWorks, and CATIA V5. He has worked as a professor of robotics, programming

and 3D design as well as participating in different entrepreneurship projects, R&D&i and product design in fields such as educational robotics and wearable technology. His research interests include smart textiles, electronic textiles, robotics, CNC technologies, PLM software, and circuit printing.



Carlos Fernando Da Silva Ramos

Carlos Ramos got his graduation from the University of Porto, Portugal, in 1986 and the PhD degree from the same university in 1993. He is Full Professor of the Department of Informatics at the Institute of Engineering – Polytechnic of Porto (ISEP-IPP). His main interests are Artificial Intelligence, Knowledge-based Systems, Decision Support Systems, Deep Learning, and Ambient Intelligence. He

was the former Director of GECAD (Research Group on Intelligent Engineering and Computing for Advanced Development and Innovation), a research unit ranked with Excellent by the Portuguese Science and Technology Foundation, being currently member of the Administration Board. He is member of the Intelligent Systems Associate Lab from Portugal. He was Vice-President of the Polytechnic of Porto from 2010 to 2018, being responsible for the areas of R&D, Innovation and Internationalization, and since April 2022 he is Pro-President of the Polytechnic of Porto for Cooperation and International Relations. He has around 500 scientific publications (90 in scientific journals), participated in 58 international and national R&D projects, coordinating 25, and supervised 13 PhD completed works. Currently he is Director of the MSc Program on Artificial Intelligence Engineering from ISEP/IPP and member of the External Evaluation Commission of the Portuguese Agency for Evaluation and Accreditation of Higher Education for the area of Informatics for Polytechnics.