

A Temporal Distributed Group Decision Support System Based on Multi-Criteria Analysis

Sofiane Khiat*, Djamilia Hamdadou

Computer Science Laboratory of Oran (LIO) - Université Oran1, Oran (Algeria)

Received 8 August 2018 | Accepted 15 February 2019 | Published 8 March 2019



ABSTRACT

Decision support consists of proposing tasks and projects by taking into account temporal constraints and the use of resources with the aim of finding a compromise solution between several alternatives. Indeed, on the one hand, centralized resolution systems and methods are generally inappropriate to the real case because of the local unavailability of decision makers. On the other hand, the data of the decisional problem are generally poorly expressed in a negotiation environment. Other techniques and approaches treat the same decision-making problem and impose a distributed vision for coherent decisions. For this purpose, Multi-Agent Systems (MAS) allow modeling a distributed resolution of the group decision support problem. In this article, we propose a new model of a multi-criteria group decision support system based on a multi-agent system modeling a spatial problem. We consider that each decision maker is assimilated to an agent that has a decision-making autonomy, in which he interacts with other agents in the debate through a negotiation process in order to reach an acceptable compromise. In this study, we propose coordination mechanisms among agents to highlight the simulated negotiation. Therefore, the proposed system finds a solution before fixed deadlines' time expire. We experiment the suggested negotiation model to solve the decisional problem of spatial localization in territory planning.

KEYWORDS

Group Decision Support System, Spatio Temporal Modeling, Multi Agent Systems, Multicriteria Decision Analysis, Negotiation, Territory Planning.

DOI: 10.9781/ijimai.2019.03.002

I. INTRODUCTION

THE field of decision support has been the subject of research conducted by several scientists of various fields. Therefore, it has constituted an attractive pole for different studies and applications. Among these applications, we find several cases which are related to problems with spatial reference: urban and regional planning, transport, management of water resources, environmental management, evaluation of the territory and location of industrial activities, etc. The problems which are related to the area of spatial decision support focus on the selection of geographical sites [14] [4] [37]. This latter is based on the choice between several sets of physical criteria [12] [13].

Moreover, decision support systems aim to help decision makers in their tasks by providing them with all the relevant elements for decision-making and spatial planning. In fact, territorial decision support involves several conflicting criteria, whose importance are not the same. The territorial decision support involves several decision-makers and institutions, which generally have divergent preferences and objectives where various points of view must be taken into account for a final decision [23]. The decision appears as a compromise between several interests and divergent points of view that imply the use of a negotiation strategy between the various involved actors who must take decisions as quickly as possible by taking into account a functioning constrained time. Consequently, this permits to obtain an answer to an interrogation before a given deadline in order to allow decision makers to act as quickly and appropriately as possible.

Territory planning (TP) is based on a prospective and strategic vision that takes into account the potential, physical, social, economic, and environmental constraints of the concerned territory [14]. This type of problem involves several decision makers (persons and institutions) with different interests who have generally divergent preferences and objectives and whose different points of view must be taken into account for public decision.

The realization of spatial localization in TP relies on mathematical methods and computer tools such as geographical information systems (GIS). The application of GIS is oriented to several areas: urban development [39], environmental management [10], the territory evaluation [12], industrial diagnosis [41] etc.

More particularly, spatial decision support systems are interesting, especially in the development of a model of group decision support which is dedicated to the problems of space localization in TP: the problem which entails the search for a surface on a geographical map satisfying a set of criteria and finding a compromise between several interests that appeal to the expertise of several people, particularly those which are concerned by the decision.

However, the group of decision-makers will be modeled by a set of entities called computer agents. These agents represent each decision-maker in a multi-agent system (MAS) [11] [27].

The problem addressed in the current study concerns the proposition of a system that models the different decision makers who have their own information, constraints, decision strategies, preferences, and objectives generally not shared or communicated. Hence, the need for a negotiation process integrated into a group decision support system (GDSS) allows finding a common agreement for this group, in the face of a conflict. Several reasons can be mentioned besides the group and

* Corresponding author.

E-mail address: khiat.sofiane@gmail.com

the decision-making for a common goal, which we quote:

1. *The multi-criteria aspect* (“*several conditions per alternative* “): allows the identification and the measurement of the alternatives or solutions on which the decision will be made. It is therefore to build a family of criteria that can represent as closely as possible the costs and benefits of the actions
2. *The geographical distribution* of decision-making actors is justified by organizational realities. Decision-making can thus bring together distributed actors on one or more sites.
3. *The bounded temporal dimension* (“*a definite period of time*”) is essential because it induces a beginning and an end to the activity, so it is ensured by an evaluation strategy and the means of communication.

The research work conducted in this study is summarized, in this paper, as follows: In section 2, we present a literature review on group decision support systems, their characteristics, and their topological evolution. In section 3, we propose solutions related to the problem of distributed negotiation with a specific deadline. Section 4 is dedicated to describe our proposal for a distributed group decision support system. In Section 5, we describe how the proposed system works. Section 6 is dedicated to the description of the design and implementation of the proposed approaches.

Finally, we will conclude this article by summarizing the various contributions we have proposed to the problem of distribution and negotiation in group decision support systems. We will end by reciting some tracks of research that seem relevant to the problem dealt with in this study.

II. RELATED WORK

The presented work is integrated in the context of Decision Support Systems (DSS). The later is considered in two main dimensions: the individual and the collective dimension.

The individual dimension is to provide a decision support to an expert decision maker in a field and to propose the resolution of a particular problem. Solving the problem follows a pre-established decision support process that is based on breaking down the problem into tasks and subtasks to have a satisfactory solution. Several decision support systems with a single decision maker have been proposed by using multi-criteria analysis methods:

In [1], the authors presented a method of multicriteria decision support to evaluate the decision of internalization / outsourcing as a part of a sustainable development strategy and they evaluate the strategic importance of the activities. The proposed method makes it possible to calculate an overall performance index by using the method AHP (Analytical Hierarchy Process) with indicators. In [2], the authors presented a case study on the implementation of a multi-criteria approach to the performance and risk exposure of a bank. The proposed methodology is based on the PROMETHEE II method implemented in an integrated decision-making system.

In the same optics as our research, other studies have been conducted by exploiting geographic information systems (GIS): In [3], a methodology for evaluating built-up urban space was proposed (authors developed a decision support system for housing valuation). This system integrates a problem editor, a database management module, a set of multi-criteria decision support methods and an adequate human-computer interface that can be integrated with GIS tools. In [4], the objective was to provide a decision support in urban infrastructure which is planned to users. In addition, visualization of available alternatives on maps provide an added value to decision-making processes in urban infrastructure assessment issues. The development of this system was motivated by a real urban case study.

In [38] a fuzzy hierarchical analysis method (FAHP) combined with a geographical information system (GIS) has been proposed. The authors presented a process for ranking industrial sites in Algeria. The proposed process of decision-making is based on the AHP method. Also the GIS is used to prepare geographic data in screening phase and to visualize ranked zones on a map in the evaluation phase. In the same area of use of the AHP multicriteria method and techniques that deal with transport problems, in [40] an analysis of the factors of urban mobility in the situation of cities has been proposed. The objective is to take into consideration all the elements involved in mobility in urban environments, in which their behavior was studied.

The works cited above do not always reflect reality because decision-making does not concern a single decision-maker, which has led to the development of group decision support systems, where a set of decision-makers, sometimes geographically dispersed, with different values and with potentially conflicting issues are involved. As a result, we identify the second dimension, the collective one.

The collective dimension concerns the collaborative aspect because it consists of providing collective decision support, where each decision-maker is involved in each step of the decision-making process. As a consequence, several works have been proposed:

In [5], a group decision model based on ELECTRE GD has been proposed. It is a group decision method constructed on ELECTRE III. The proposed model generates a collective solution that helps decision makers with different interests to reach (through an iterative process) an agreement on how to classify their alternatives. In [6], a methodology for remote group decision support (GDM) in case of emergency is proposed. In this model, some decision-makers are identified to formulate a group decision-making framework and a multi-criteria decision-making process is carried out, in which different results are obtained from diverse decision makers to verify the effectiveness of emergency management.

Other works have been invested in coordination between decision-makers, for a global decision-making, which was considered as a common interest. Cao and all [7] propose a theoretical vision of coordination in the use of the multi-criteria tools for the decision support system (DSS) intended for the groups. The authors proposed an extension by formulating parallel and sequential coordination methods for the distribution of multi-criteria tools. These methods can be used by DSS users to coordinate and structure the distribution of multi-criteria tools for groups. The study proposed in [8] had as main objective the implementation of parallel and sequential coordination methods in a web-based multicriteria group decision support system. The authors presented two methods of coordination that influenced the collaborative group decision process and the final consensual solution in the context of distributed group decision support multicriteria analysis. In [9] the authors set up a web-based multicriteria decision support system, which solved multi-criteria arrangement problems in a collaborative group of decision makers in sequential or parallel coordination mode and in a distributed and asynchronous environment.

In a context of simulating the behavior of decision-makers, several researchers have proposed group decision support systems (GDSS) with architectures based on multi-agent modeling (MAS). The decision-makers are modeled in such systems by intelligent agents. Below, we are going to identify some works on this aspect.

The author in [10] made a simulator based on a multi-agent system whose objective was to provide the negotiators with an instrument to test the consequences of a regulation in order to reach an acceptable compromise. In [11], a three-layer system structure had been proposed. This structure allowed for the implementation of a distributed intelligent decision-making system for a marketing decision. The authors developed the marketing system supported by a distributed decision support.

The modelling of decision-makers by intelligent agents in a group decision support system is a very interesting field in current research because it has become more important especially when the data are of spatial type (geographic area). Several researchers have proposed GDSS models to address spatial location issues by considering a set of decision-makers. However, few are the works that considered the multi-criteria aspect and the multi actors aspect at the same time. The main existing works in the literature were carried out in our research team. Consequently, we are going to quote the most significant works carried out:

In [12], the authors proposed a decision quality optimization study in the context of spatial data management using a decision support model. The suggested model allowed experts to carry out diagnoses and proposed adapted alternatives by modelling negotiation and multi-stakeholder participation using multi-agent systems. In [13], the authors' objective was to integrate multi-criteria analysis methods (MCAM) into a decision support system based on SOLAP technology (Spatial On-Line Analytical Processing), which was modeled and implemented as part of decision support systems dedicated to epidemiological surveillance. In [14], the authors proposed a strategy for the design and development of a spatial group decision support system and multicriterion. A multi-agent modeling (MAS) with a negotiation protocol based on mediation is proposed to conduct the spatial localization process. The latter was implemented in the territory planning. In the context of group decision support systems (GDSS) that model negotiation, a coordinator is involved in order to help decision-makers to negotiate [15]. The main role of a coordinator is to find a satisfactory compromise for all decision-makers. The Negotiation in multi-agent systems (MAS) gives growth to two different approaches [16], [17]:

1. *Analytical and normative approach based on game theory.* Zlotkin and Rosenschein [18] applied game theory tools in multi-agent systems (MAS).
2. *An approach based on the behavior of actors in the negotiation process.* Most of the works in this direction lead to the development of negotiation protocols. The best known among them is the Contract Net Protocol (CNP) [19] developed for coordination.

The first approach can only be used if the mathematical models support negotiation. It has an analytical or numerical solution (Monte Carlo method for example) [20]. The second is the only one possible to explore complex processes, in which relationships between agents are not reducible to mathematical models [10].

We have made improvements to integrate the previous approaches into a distributed decision support system proposed in this article. It is obvious that a large number of solutions and the distribution of choices, makes a large part of the decision support system. The metaheuristic based on time constraints has proved to be an efficient decision support tool for assignment problem solving. For example, in [42] the authors presented an optimization algorithm that solved a Rich Vehicle Routing Problem (RVRP) and arose from a research project carried out for an important Spanish distribution company.

Lastly, in a coordination strategy, it is obvious that a negotiation by proposal of solutions cannot be buckled to infinity. As a result, the strategy that we proposed takes into account time parameter and proposes a policy of the time management.

Claude Duvallat [21] was mainly interested in the study of the real time aspect in multi-agent systems. He proposed ANYMAS model (ANYtime MultiAgents System) for the design of a real-time multi-agent system (RTMAS) based on the use of anytime algorithms.

In this study, we suggest a model of a decision support system based on agents. The decision makers who engage in decision making can be geographically remote (distributed), where each

decision maker is modeled in this system by an intelligent agent. All agents follow a collective decision support process guided by an elected coordinator agent. Such a system is propped by negotiation simulation mechanisms.

III. OUR CONTRIBUTION

We place our contribution in the context of critical decision-making situations, where collective decision-making activities are generally characterized by synchronous cooperation sessions within *distributed* environments which are evolving and often unpredictable related to problems of *multiplicity of decision-makers and their preferences*.

- *Distributed (location problem):* Decision-makers act simultaneously and from distributed access points on shared objects by following implicit or explicit coordination rules and by using a set of tools that allow them to progress in a coordinated manner.
- *Multi criteria and multi decision makers:* The members who have different interests, skills, and experiences express their preferences in the form of a choice between several possible solutions to several criteria, which can relatively be of different nature: economic, social, environmental, technical ect. Decision making requires a synergy of efforts from several members, so that each one of them can use their know-how.

The main contribution proposed, in this article, particularly in the area of collaborative decision support, is to organize the performance of interdependent tasks over time by taking into account the temporal constraints and the use of data with the objective of optimizing one or more criteria. The methods of traditional resolution known as centralized, are generally poorly adapted to the real case because the data is geographically dispersed. For this purpose, the multi-agent systems (MAS) constitute a paradigm quite appropriate and powerful which allow the modeling and the distributed resolution of the spatial location problem in a Territory Planning (TP). In this work, we are interested in a problem which consists of searching for a surface on a geographical map that satisfies a set of criteria. In addition, we propose to model and solve this problem in a distributed way by using a multi-agent approach. We consider that each decision maker is assimilated to an agent who has a decisional autonomy, and who can also cooperates with the other agents in order to reach a mutually acceptable global solution. Negotiation is a powerful mechanism for finding mutually acceptable compromises. Literary, the proposed approaches are based on a multilateral protocol that have a coordinator agent and a group of negotiators participating agents, who try to find a compromise that best satisfies the various decision-makers. Indeed, our objective is to propose mechanisms of cooperation between agents by electing one agent among the group of agents in order to ensure consistency in decisions that are locally taken. This new approach is encouraging because it looks like the way humans negotiate. During a negotiation, the proposed solutions allow the agents to interact with an offer or a proposal related to their points of view, and their preferences. The main objective of our contribution is to:

- Design, develop, and implement a Group Decision Support System (GDSS) to represent the multiplicity and diversity of actors by proposing a negotiation protocol.
- Other more specific objectives are targeted:
- Deploying the proposed GDSS in a distributed architecture.
- Representing the preferences of each decision maker by exploiting the main advantages offered by multi criteria analysis methods.
- Guarantying the temporary aspect basing on a negotiation strategy.

IV. THE PROPOSED DECISION SUPPORT SYSTEM

The problem addressed consists in seeking a view as precise as possible of a given situation and obtaining a maximum of relevant information that satisfy a set of criteria and preferences which makes it possible to reach a consensus.

For that, we implement a distributed group decision support system operating in three main phases: (1) pre-negotiation; (2) negotiation; and (3) post-negotiation. The proposed system is illustrated in Fig. 1.

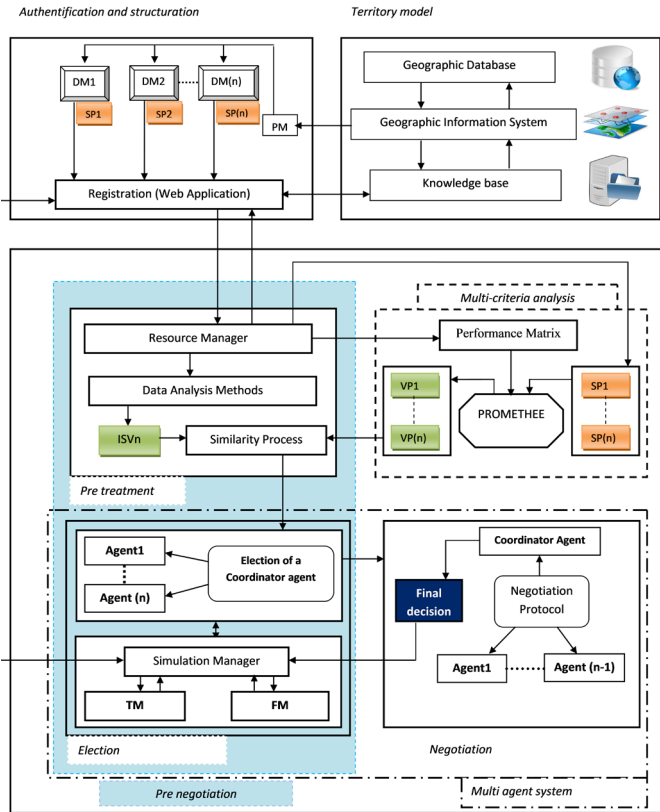

Fig. 1. Proposed Group Decision System.

The “Pre-negotiation” phase allows exploring and opening the negotiation space. The last phase “Post-negotiation” closes this space. The second phase “negotiation” includes an important stage known as a proposal of solution (decision support). The later contains four main stages that constitute the building blocks of any decision-making process, whose Simon’s [22] model shows the different steps for individual decision making.

Table I summarizes some concepts used in the proposed decisional approach:

A. Authentication and Structuring

For a distributed group decision problem, each decision maker in this group is modeled by an agent of a MAS, who allows the interaction between the different agents by a negotiation process. Accordingly, each decision-maker is located in geographically dispersed locations and he must involve his preferences through a web application. This phase also allows to display the final solution in output (the solution of the problem). This solution is stored in the knowledge base taking into account multiple possible uses of solutions to evaluate scenarios for similar future situations.

TABLE I. DESCRIPTION OF ACRONYMS

Acronyms	Description	Role
PM	Performance Matrix	A set of data describing the decisional problem, each performance represents the evaluation of each alternative against each of the criteria.
SP _i	Subjective parameters of each decision maker i	Values that express the preferences of the each decision-maker (weight of a criterion, its preference and indifference).
ISV _n	Initial Solution Vectors	A ranking of all the alternatives in a vector by a specific order.
VP	Vector of Preference	The vector that expresses the ranking of alternatives for each decision-maker after execution of the multi-criteria method.
TM	Time Manager	Time controller by event sequence.
FM	Fault Manager	Failure of a Technical and physical system controller.
n	Number of decision makers involved in solving the decision problem	Number of decision makers counter.
DM _i	Decision makers from 1 to n	System users.
PROMETHEE	Preference Ranking Organization METHod for Enrichment Evaluations	A multicriteria analysis method based on the elementary mechanism which is the comparison of the alternatives according to each criterion(two by two).

B. Territory Model

This model makes possible to adjust the analysis of the object and the space, to explain why we find this or that phenomenon here and not elsewhere, to interrogate a set of modules to provide a set of possible solutions to a given situation or problem, and to manage modifications and recordings in the knowledge base. It has its own structure and functioning, it inscribes itself in the space and the time (spatio-temporal scales). The territorial model comprises three components which are ultimately in interaction.

1. The Geographic Information System Module GIS

It is an information system designed to collect, store, process, analyze, manage, and present all types of spatial and geographic data. The essential function of GIS is to enable knowledge management of the territory, it is able to [23]:

- Manage the geographic database.
- Archive information in a knowledge base.
- Manipulate and query geographic databases.
- Provide a spatial representation of the studied systems.
- Visualize the data.

When decision-makers are able to identify alternatives and criteria through using the analytical capabilities of GIS in which a value (score) is assigned to each criterion the set of alternatives and their scores relative to the different criteria constitutes the matrix evaluation (Matrix Performance).

2. The Geographic Database Module

It is a set of spatial and non-spatial data structured and organized to be searchable and analyzable interactively or automatically. A geographic

database usually relates to a defined area. It is managed by GIS software. Furthermore, It integrates the data itself as well as their metadata.

3. The Knowledge Base Module

This knowledge base consists of the decision-making session's directory. It is implemented to save and store the data related to the final decision, the trace of decision-making sessions, intermediate results, system elements, and shared documents. Its main purpose is to store all the solved cases in the past (problems and their solutions) and to provide these results to decision-makers. The flowchart in Fig. 2 shows this interaction.

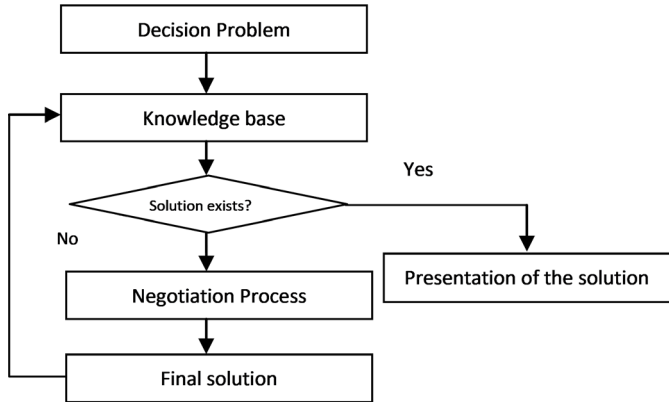

Fig. 2. Flowchart of a knowledge base decision support system.

C. Negotiation Model

The proposed system illustrated in Fig. 1 is composed of several modules which deals with a given group decision problem where the negotiation module is composed, mainly, of four sub-modules described below.

1. The Pre-Negotiation Module

We identify two major elements that mark this phase: *pretreatment* (pre-processing) and *election*. These two elements are ubiquitous in the rest of the decision-making process:

Pretreatment: In order to better adapt our proposed system to control mechanisms, we have equipped this module by a data manager which is able to detect any hardware and software infrastructure included in the system to better keep the environment stable, especially it is important to maintain an initial state between the system and the users. This makes it possible to define the deadlines in a negotiation process and control the interactions of decision-makers. The challenge of this notion is to allow the best choice of constraint that can express the best decision. The second notion consists of ranking the alternatives from the best to the worst without the notion of preference being present. This allows to assign to each available alternative a rank (a ranking vector). This approach is ensured by the data analysis method to solve this problem. Accordingly, we have exploited the different steps of this approach:

- Clustering (“solution categorization”).
- Data analysis method (“choice of the best criterion”).

The clustering consists of grouping objects in order to build predefined categories or classes. This type is a part of the classification problems. This is done by using a set of examples named as a set of solutions or alternatives (learning set). They are made up of objects, whose category membership is not known (unsupervised aspect). Methods that solve this type of problem can be used to build / discover categories. Moreover, this type of method is used when the decision maker is not able to specify the categories [24].

However, the data analysis method makes it possible to choose the best criterion. In this paper, we are interested in determining a new measure for proposing solutions to decision-makers adapted to problems of multi-criteria decision support. This technique makes possible to classify the solutions using the unsupervised classification (use of k-means) in order to apply a learning algorithm. It is a question of finding a partitioning of the individuals which better represents the classes of each individual. This partition is then presented in the form of a decision tree.

Election: after obtaining the ranking of all the alternatives in a vector that will be called vector of initial solutions, this is compared to each preference vector (VP) of the decision maker to have the best similarity, in order to choose a preference vector of a decision-maker (among all decision-makers) that contains a ranking of solutions similar to the vector of initial solutions. This makes it possible to choose the participant who will be responsible for the good progress of the negotiation named the coordinator (in MAS). Additionally, this step is ensured by the similarity process. A time manager is set up to ensure the negotiation within the deadlines, to detect other breakdowns, and the event of exceeding time deadlines. The fault manager will automatically trigger if an agent disappears or leaves the negotiation. Therefore, in this case the negotiation must be restarted.

The two steps mentioned above are placed in a distributed decision support system, in which a simulation manager is set up to choose the best actor within a well-defined time interval in order to solve a specific decision problem.

2. The Multicriteria Analysis Module

Multicriteria decision analysis consists of constructing models that deal with decision problems taking into account several criteria. Each criterion addresses a set of homogeneous consequences. This is an important factor to evaluate a given scenario or to appreciate an occasion of alternative [25] and that the decision-maker must consider which are important and which are less important. The Multi Criterion Analysis (MCA) allows to deal with the multiplicity, the divergence, and the nature (quantitative or qualitative) of the criteria in order to reach acceptable compromises [41].

MCA is based on a coherent of criteria's family constructed and started from a set of consequences or evaluation (performance) of each alternative of $A = \{a_1, a_2, \dots, a_n\}$ on a family of criteria $F = \{g_1, \dots, g_n\}$ which is provided by $g_j(a_i)$. These evaluations can be summarized in Table II. The application of this definition is called a Table of Performance (Performance Matrix).

TABLE II. PERFORMANCE MATRIX

	g1	g2	g(n)
a1	g1(a1)	g2(a1)	gn(a1)
a2	g1(a2)	g2(a2)	gn(a2)
.....
a(n)	g1(an)	g2(an)	gn(an)

In the context of our study, we chose the multi-criteria analysis method PROMETHEE II [26] which consists of ranking the alternatives according to an order of preference. This problem seeks to obtain a complete preorder on the set A of each participant, who must introduce his preferences (in the form of subjective parameters), depending on the application and the situation treated. Table III summarizes the various subjective parameters used in the multi-criteria method. They can be classified into two categories: “intercriteria parameters” and “intracriteria parameters” [23].

TABLE III. SUBJECTIVE PARAMETERS

Parameters	Symbol	Meaning
weight	P_j	Qualifies the relative importance of a given criterion C_j with respect to the other criteria.
Preference threshold	PT_j	The threshold at which the difference between the two alternatives is perceptible and makes one preferable to the other.
Veto threshold	Vt_j	Allows fixing an additional notion. If this threshold is exceeded on a criterion, then the alternative cannot be taken into consideration. Thus, it defines an intolerable situation for one of the participants.
Indifference threshold	It_j	This is the smallest significant difference. Below that threshold, it is impossible to separate the two actions.

The first characteristic of the proposed group decision support system is decentralization. Such a system is lacking a central coordinator entity for the organization of the multi-agent system which involves a negotiation between the participants.

3. The Multi-Agent System Module MAS

In the first place, it is necessary that the information is available to decision-makers as soon as possible. However, Multi-Agent Systems (MAS) are particularly appropriate when dealing with Group Decision Support Systems (GDSS). Indeed, the agents make possible to reproduce the global functioning of a GDSS from the entities which compose it (GDSS) and interactions. The MAS is a tool which makes it possible to express an application and a behavior of the decision makers by autonomous agents, who play roles and render services in an organization.

The different distributed decision-makers who have their own objectives are modeled by agents that have their own objectives and preferences. This implies that the decision process is distributed among the different entities which are basically involved in this group decision via a web application. The MAS allows the representation of interactions between various entities that can cooperate, negotiate, and communicate. In addition, an agent that evolves in an environment must be able to receive information from this environment, and to act in the same environment by following a decided behavior according to the agent's reasoning. The agent is characterized by his architecture and his behavior, so that he can accomplish what is expected of him. Depending on the architectures and capacities, the agents are classified into several types that qualify them as cognitive, reactive, or hybrid [27].

In the context of our study, our system involves reactive agents. Each agent is controlled by a time manager for its overall operation and interactions with other agent in the platform.

For this purpose, we endow the MAS module with a negotiation protocol based on the election that involves one negotiator agent (coordinator agent) among the others, and a set of participating agents who represent different actors that are involved in a collective decision. We are interested in a particular application class: applications based on distributed group decision support systems by intelligent agents. In this class of applications, we will look for a final decision in relation to a given situation within a constrained time frame. Therefore, we will find a solution before fixed deadlines time expires. Fig. 3 illustrates the interaction between the negotiator agent and a participating agent who is controlled by this environment.

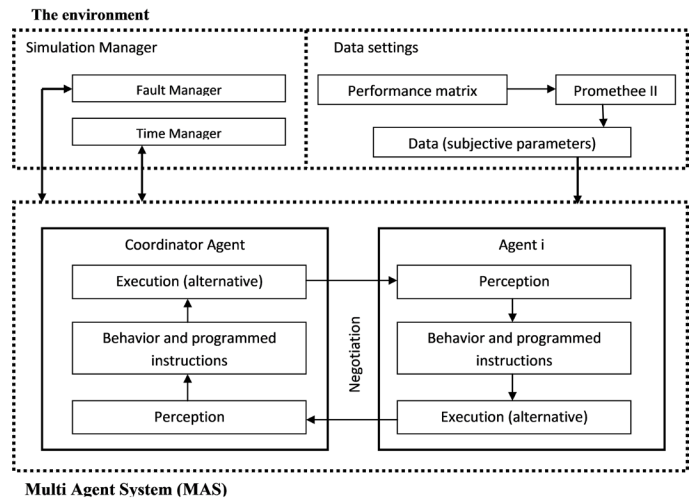

Fig. 3. Overall architecture of the proposed system.

4. The Negotiation Module

Distributed Group Decision Support System (GDSS) refers to any computer system based on a multi-agent model, where each participant can be an offeror or applicant of a service in the face of a conflict, as opposed to the Client / Server model, where each participant has a specific role (either he offers a service, which makes him a server "elected agent", or he is a service requester, which makes him a client).

Our contribution is to search for a surface on a geographical map that satisfies a set of criteria and finds a common agreement between the participants. Basically, this includes negotiation ensured by an elected coordinator, who offers solutions (alternative) from an initial vector of solutions.

In our research, we are interested in the negotiation in multi-agent systems (MAS). In such a system, the negotiation can resolve conflict situations between participants through the following characteristics:

- *The proposition of solutions* (alternatives) through a negotiation protocol that can be carried out directly from individual to individual [28].
- *The use of a coordinator* [29]: the process of negotiation based on sending messages between a coordinator and participants through a protocol is the most widely used, easily adapted one that actually models the way humans react to each other.
- *The election of a coordinator* among all participants to decentralize the negotiation protocol and distribute it.

V. THE PROCESS OF PROPOSED SYSTEM

In this section, we present a flowchart that illustrates the collaborative and distributed decision support process based on our observations and our analysis of the models proposed in the literature [30], [7] and adapted to our design of cooperative decision support modules. The model we propose is able to support the decision-making process in the particular multi-decision-maker context which is distributed with time constraints.

The flowchart in Fig. 4, demonstrates the sequence and approach taken by the system to conduct the collective distributed decision support process.

The decision-making flowchart is divided into several parts. The first part is reserved for the notion of initiation of the decision-making process and the formulation of the problem.

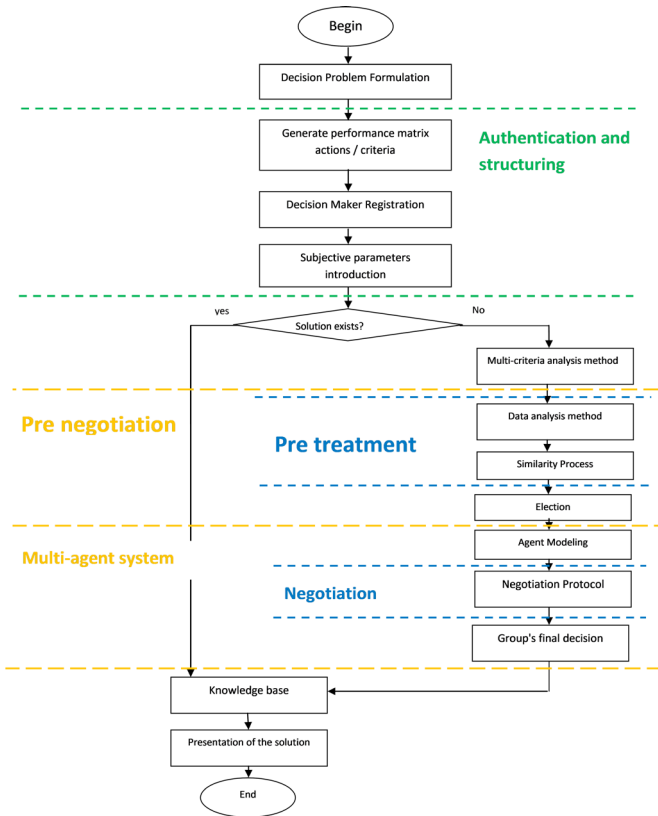

Fig. 4. Flowchart of the proposed approach.

At this level, the system is responsible for several tasks mentioned below:

1. The determination of data (performance matrix);
2. The invitation of decision makers;
3. The configuration of the decision-making environment (triggering and managing the temporal sequence) ;
4. The creation of a representation and a shared context (registration of decision makers).

The decision support model that we propose allows the decision maker to describe their preferences through a web application to solve a decision problem. The system tries to check if the solution already exists, if yes, the adapted proposal to this problem is exposed directly to the decision-makers, otherwise it is a new problem that requires the execution of the system processes to start another part of multi-criteria analysis; this notion is described in section V.A.

A decision support environment must therefore allow the simulation manager to trigger decision-making mechanisms; some of them are related to the time management and others are related to the management of breakdowns and tasks.

To summarize, the simulation manager proposes a list of decision-makers according to their registration order and profiles. The simulation manager is therefore responsible for choosing a negotiation coordinator and triggering other mechanism, such as the time manager, which synchronizes processes and determines the temporary deadlines of the responses (the decisions) in the negotiation phase. The measures of the time manager will be explained in the following sections.

A. PROMETHEE Method

It is a multi-criteria decision support analysis method, and it is the acronym for Preference Ranking Organisation METHOD for Enrichment Evaluations. PROMETHEE was proposed for the first time by Jean Pierre Brans [26].

PROMETHEE belongs to the family of outclassing methods, in which two particular mathematical treatments are proposed: the first makes it possible to classify the alternatives in a partial pre-order that leads to incomparability (the PROMETHEE I method). The second allows classifying the potential alternatives according to a total pre-order (PROMETHEE II method).

These methods address any multi-criteria problem of the type:

TAB $\{g_1(a_1), g_2(a_2), \dots, g_n(a_n) / a \in A\}$ where $A = \{a_1, a_2, \dots, a_m\}$ is a set of alternatives evaluated on a set of n criteria $G = \{g_1, g_2, \dots, g_n\}$. Let $F = \{1, 2, \dots, n\}$ be the set of criteria indices.

The data relating to such a problem can be represented in a table TAB ($n \times m$) of dimension called performance matrix. Detailed in section IV.C.2.

The PROMETHEE method is exploited by each decision maker. Besides, it consists of establishing a process of numerical comparison of each alternative compared to all other alternatives. Consequently, it is possible to calculate the most important (merit) or the least important (demerit) of each alternative compared to all the others [26]. The result of this comparison allows the ordered ranking of alternatives (solutions) in a table called ordered ranking vector for each decision-maker. Therefore, it must consider a degree of two important parameters: the threshold of preference and indifference chosen quite easily by the decision-maker.

Both methods PROMETHEE I and II have the same initial reasoning, but their objectives are different in terms of classification of alternatives. PROMETHEE I makes it possible to identify relationships by a partial classification; whereas PROMETHEE II provides a classification of all the actions known as a total aggregation. We are interested in the PROMETHEE II method because of its advantages.

1. Why PROMETHEE II

The PROMETHEE II method is among the most used methods in the category of outranking methods, because it offers a number of advantages of which we quote [31]:

1. It integrates the recent developments in the modeling of preferences in a simple way.
2. It has a mathematical basis, so that it programs and improves its functionality easily.
3. It builds a valued outranking upgrade that reflects the preference intensity.
4. It provides the decision-maker with a complete and partial ranking of the alternatives to choose.

We chose the PROMETHEE II method because it deals with a large number of alternatives, whereas the other methods such as AHP treat a limited set of alternatives [38].

In the next section and in the decision-making processes, the system must provide decision-makers with several tools to help them to negotiate. This latter is realized by a protocol which makes it possible to propose a set of solutions (alternatives) with an order relationship between various proposals. This modeling step is chained by a data analysis method and a similarity process that we explain in section VI.2. It is generally carried out with time constraints.

B. Classification and Similarity Process

We summarize our concept and our approach in several phases:

- *Phase 1:* the integration of the decision maker's preferences via the web application in the PROMETHEE multicriteria method. This phase is independent from the others because it is autonomous as each decision maker has its own storage vector.
- *Phase 2:* The clustering phase, in which a k-means clustering algorithm is applied. The k-means is executed on the data set without taking into consideration the subjective nature of the problem.

- *Phase 3:* The classification of criteria based on preference relationships generated by phase 2 i.e. an application of the decision tree that allows us to have order of a ranking by a tree relationship with the notion of the greatest possible gain.
- *Phase 4:* The verification of the quality of the classification's results by an agent's election (mediating agent), this latter controls the negotiation process through several simulations.

The first phase is realized by the PROMETHEE method. In the following phase, we explain the impact of the clustering phase on the election process.

1. Clustering and Election Process

We process the clustering method (phase2) according to the following constraints:

Either a clustering problem of the performance matrix defined by:

$A = \{a1, a2 \dots am\}$ a set of objects (alternatives).

$G = \{g1, g2 \dots gn\}$ a set of criteria associated with set A.

The problem is to find a clustering method that represents the objects in set A. To do this, we build:

1. A performance matrix with quantitative parameters.
2. $C = \{1, 2, \dots, n\}$ a group category set defined on all objects. This set is categorized by classes denoted by numbers ($c1, c2, c3, \dots, cn$) and obtained by applying a clustering method.

In order to find a clustering method, we consider the problem of clustering as a problem of choice between several criteria which better represent the set of solutions (objects or alternatives). As a consequence, we chose the K-Means Method that aims to group a set of solutions together in the form of labeled classes [32]. Fig. 5 shows the clustering of the performance matrix (PM) processed by k-Means.

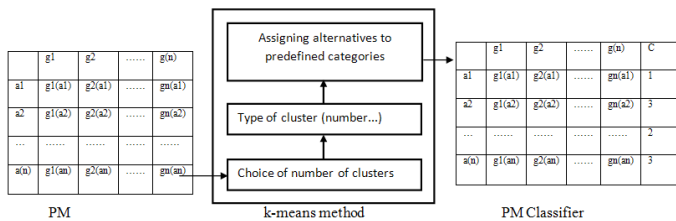

Fig. 5. The application of a clustering method.

Why K-Means

Different clustering methods and algorithms have been proposed and developed in literature. Studies have shown that no method is better than others on all clustering problems [33]. In this context, the K-Means algorithm is one of the best known and most used algorithms. It is based on an iterative process that is easy to program and adapt. However, the main advantage of this technique is its linear complexity in relation to the number of objects to that will be treated.

The objective of the next steps (phases 3 and 4) is to propose a new formulation of the coordination problem in GDSS using negotiation concepts. In this section we firstly define the application of decision trees on all alternatives and criteria. Then, we detail the two main developed contributions in this article to solve this type of problem, namely as the similarity process and the election of the coordinator agent. Finally, we describe the negotiation protocol.

2. Decision Tree

Is the classification phase of the criteria (phase 3). It is a question of finding partitions that better represent individuals (solutions) and model all the attributes (criteria) in the form of a decision tree. We take a set of classified data as an input (performance matrix processed by

the K-Means Method), and we provide on output a tree that looks like an orientation diagram.

ID3 is one of the reference algorithms and the most used in the supervised classification type. The ID3 is founded on information theory research [35], this algorithm is based on examples already classified in a set of classes (result of the K-Means Method) that produces a decision tree [34].

Why ID3

We chose the ID3 algorithm in the design of our system because the popularity of this algorithm rests on its simplicity, especially from the point of view of the ease of implementation [36].

3. Similarity Process and Election in a Multi-Agent Environment

The objective of the process is to use the knowledge gained in the result of the decision tree to improve the quality of the final result. Indeed, the use of a reference vector for a comparison between several rankings increases the robustness of the solution. This happens by avoiding the problems related to the outsourcing of coordination and the processing related to the classifications of the proposals to reach the final solution. The similarity process consists of:

- Selecting the root of the decision tree (top node) that represents the most important attribute.
- Assigning a sort order of more to less important of the set of examples (alternatives) with respect to the selected attribute.
- Defining a reference vector called the initial solution vector that contains examples (alternatives) generated by the ranking order assigned to the solutions.
- Comparing a decision-maker's ranking vector with the initial solution vector, a similarity index becomes more important when the two vectors are similar in terms of ranking solutions.
- Choosing a ranking vector that corresponds to a decision-maker by the greatest similarity assessment.

In this step, the process carries out a series of evaluations of each ranking (triggered the fault manager in case the decision maker leaves the negotiation). This process is able to manage the failure by choosing the second ranking vector. This latter corresponds to the best second similarity index. It is an operational process that involves the selection of a ranking for an election of a decision-maker who has the most appropriate storage. Fig. 6 illustrates the selection of the ranking most similar to the initial solution vector.

Our objective is not to reproduce the operation of the similarity process automatically to choose a ranking vector if the process finds two or more appropriate ranking vectors, but to propose a framework for the realization of coordination between the decision-makers by an election of a ranking that models a sequence of proposals in a negotiation process.

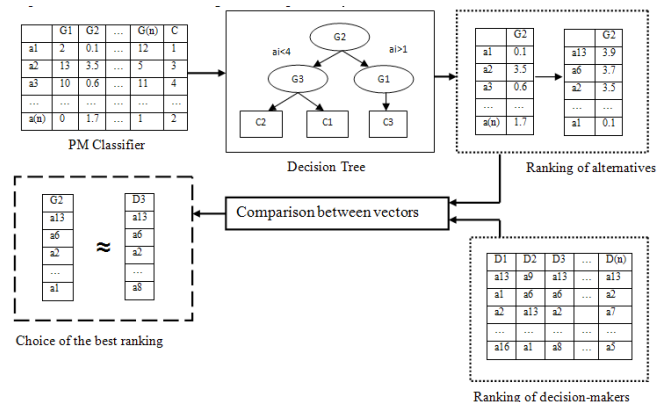

Fig. 6. Similarity Process.

Fundamentally, our approach is to develop coordination parameters that consider the choice of a ranking vector as a reference of choice of a decision-maker. This latter ensures negotiation, not in a direct way, but by a multi agent model that provides a detailed view of decision support process.

Having a multi-agent model integrated into the group decision support system provides a management of a negotiation protocol (described and detailed in section C.3). The MAS allows to model each decision-maker by an agent and to select a coordinator agent, who has the best ranking treated by the similarity process. Besides, the selected agent (coordinator agent) mentioned above is able to:

- Ensure a smooth running of the negotiation
- Use the functional capacities of a coordinator in a suitable way in a group decision support process.
- Control the behavior of the group through time management and provide solutions to reach a global compromise.

A Multi-Agent System (MAS) is an essential tool to support a cooperative work in a decision support system. In fact, the MAS brought by a GDSS exists in the interaction between the agents through negotiation. Furthermore, the decision makers find the satisfactory solution by making acceptance checks on the machine in order to see the results. The following section describes this notion by explaining the sequence of the negotiation process.

4. The Negotiation Protocol

In a multi-agent system, negotiation is characterized by a coordination mechanism that allows directing the actions (behaviors) of agents while leaving them freedom of choice by using an appropriate protocol. Our logic of unfolding the negotiation protocol is inspired and based on a protocol proposed by Hamdadou [23], in which it is divided into two notions, the *protocol description* and *negotiation process*:

Protocol Description: this stage of the group decision support process is the stage in which solutions (alternative) are sorted. We call this a production phase (compromise) and problem solving. This process is the fact of selection of the proposals by the coordinator (elected agent) before submitting the proposed solutions to all the agents (decision-makers).

The generation of an acceptable compromise to all agents must be based on a dynamic of exchange (a confirmation sequence) between the agents (MAS) and decision makers distributed, to not exceed the temporal deadlines.

Negotiation Process: in our work, a simpler approach is proposed. This approach consists of proposing solutions (alternatives) by the coordinator of his own ranking vector. Other agents are considered autonomous, as well as they always try to satisfy their desire in order to achieve the overall objective.

Negotiation is considered as a succession of sending messages governed by different steps as described below:

- In the first step, the coordinator has the proposals of the ranking vector that corresponds to the decision-maker chosen in the similarity process. He can decide how agents can organize themselves to respond to proposals. Thereafter, the coordinator also has the power to trigger the fault manager in the event that an agent's response is no longer valid (exceeding a deadline).
- In the second step, the negotiation process begins with the coordinator agent, who sends the best proposal at the respective time (the first solution located at the first location in the ranking vector and so on).
- In the third step the coordinator evaluates the answers provided by the other agents; he counts the number of participating agents who have accepted his proposal. If this number is greater than or equal to a threshold, then the negotiation is successful. Else

the negotiation continues with several iterations of exchange of proposals and counter-proposals.

- The last step consists of a compromise at a coordinator level, As soon as all the answers of the participating agents are received; it communicates the best proposal to all the participants who are present in the negotiation process.

These last two steps are repeated until only one proposal remains, or the available time to negotiate has elapsed.

The coordinator has three features:

1. The first is to propose to each agent a solution (alternative), and to evaluate the time intervals for accepting responses by triggering the time manager.
2. The second is to measure the responses sent by the participating agents by a threshold. Also, the coordinator has the power to trigger the fault manager in order to eliminate failed agents. If the coordinator falls down, the fault manager tries to reactivate the similarity process.
3. The last feature is to decide which proposal satisfies all agents based on their rankings, and the time limit set for the finalization of the negotiation managed by the time manager. We detail the impact of time in a multi agent system in the next section (Time Management).

Thus, we can notice that the participating agent manages two types of conversations driven by the Negotiation Protocol. This conversation is to allow each agent to accept or reject the proposal sent by the coordinator agent. Furthermore, to be able to answer the proposal, the agent consults his ranking vector. If this proposal is in the first row (the first half) of its ranking vector, then he accepts it by sending an acceptance message to the coordinator agent, if not, he sends a refuse message.

The negotiation process ends when the final solution is validated by the coordinator agent, in this case this coalition for a compromise is represented as a recommendation registered in the knowledge base and decision makers can visualize this result.

C. Time Management

Claude Duvallet [21] proposed an agent-based decision support system whose behavior is anytime. The acquisition of behavior takes place at two levels:

1. The local level: this is the agent level. The latter is endowed with anytime behavior.
2. The global level: it is the multi-agent system level, which must also have the anytime behavior.

The modular architecture of our system has been chosen as an agent-based architecture. It is then extended with additional modules to realize a distributed architecture with a negotiation protocol by adding a time management inspired by anytime behavior. The coordination agent has a threshold function, which counts the number of proposals that must not exceed a certain number (NbAT). Besides, when the threshold (number of messages exchanged) is reached by one agent, the other agents must synchronize in order to launch the reelection of another coordinating agent; i.e. the coordinator has proposed several solutions without reaching an acceptable solution to all agents. Moreover, a group of agents that triggered re-election are the candidates for a new election. For this purpose, choosing a new coordinator needs the selection of an agent that has the second high similarity threshold.

For a given agent, when its alert threshold (AT) function indicates that its communications have exceeded this threshold (1), he will then have two possibilities (See Fig. 7):

1. He sends an alert message to the coordinator (1), which counts the number of alerts (NbAT). If this number is greater than half plus one, the coordinator triggers the fault manager (3) to restart the re-election (4) (5).

2. He notifies the simulation manager (2), so that the system sends a message to the concerned decision maker to validate his choice immediately (6). If not, the agent that sends the alert is considered as a failing agent (he leaves the negotiation).

When an agent has to solve a problem, he invokes the time manager to initiate the alert threshold (for each agent). He can obtain an answer (end of negotiation) whose quality is not optimal (ranking of the final solution is not among the first ranked in its vector). In the case of having or receiving an alert, the concerned decision maker (the agent who represents the decision maker) must make his choice in relation to the solutions proposed by the coordinator to obtain the final result. Fig. 7 illustrates the role of each management mechanism in the proposed system.

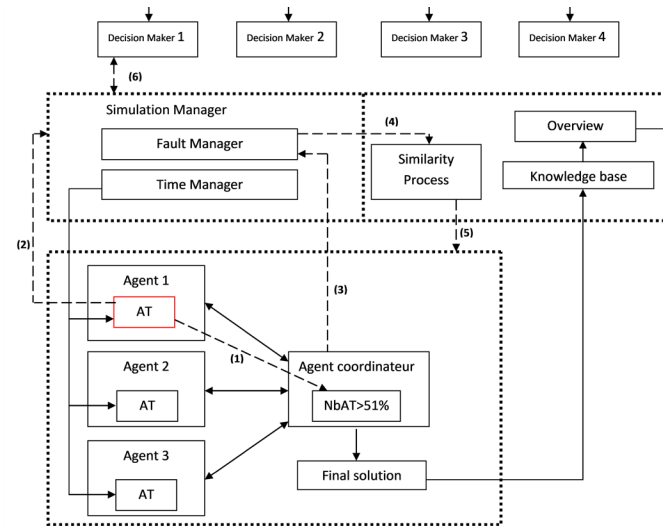

Fig. 7. Operation of the proposed system.

For each function of a mechanism, we define an associated formula. Table IV presents a summary of the different formulas used by the agents.

TABLE IV. TABLE OF MEASURING THE FUNCTIONING OF THE MECHANISMS

Appellation	Formula	Acronyms
Alert Threshold (triggering case)	$AT = \sum_{i=1}^n Pro(i)$ $if \left(AT > \left(\frac{NbrAl}{2} \right) \right) then$ $alert$	AT :Alert Threshold Pro : Proposal NbrAl: Number of Alternatives
Re-election alert	$NbAT = \sum_{i=1}^n AT$ $if \left(AT > \left(\frac{n}{2} + 1 \right) \right) then$ $re\ election$	NbAT : Number of Alert thresholds triggered by agents. n : number of agents
Overall time estimated by the time manager	$NT = \sum_{i=1}^n TPro(i)$	NT :Negotiation Time Tpro : Time of a proposal n : total number of solutions

Observing the behavior of the system will allow decision-makers to anticipate decision-making when situations of failure arise in a negotiation. This allowed us to become aware of different attractions and proposals in order to interpret the results. The estimated time allowed us to control the reactivation of functions and eliminate an iteration loop of consensus.

In order to support the representation of this approach of coordination, a UML modeling was used. It is the most useful tool for MAS modeling. Additionally, for a good representation of the different interactions between the coordinator (the elected agent) and the agents of the system, we propose a sequence diagram representation. For this diagram, the corresponding language is defined by primitives of the negotiation protocol, proposed from an agent to N agent:

Coordinating agent: sends messages to all agents:

- REQUEST (): the coordinator sends a message to the participants to indicate the beginning of the negotiation process, i.e. requesting or initiating negotiation.
- PROPOSE (): the coordinator proposes an agreement (contract) to all participating agents concerning a given solution.
- CONFIRM (): the coordinator sends a message to all agents to inform them that the negotiation is successful and the best alternative has been found.

Participating agent: The messages sent by the participants target the coordinator only. The other participants are not informed of these messages:

- INFORM (): after establishing a ranking of alternatives from the best to the worst (ranking of alternatives), each participating agent sends a life message to the coordinator (ready to negotiate).
- AGREE (): each participant indicates to the coordinator by this message that he accepts or agrees to this contract (solution proposed by the coordinator is to accept).
- REFUSE (): the participant indicates to the coordinator that his proposals are rejected. The agreement cannot be concluded in its current form and should be amended.

Fig. 8 illustrates the sequencing of these interactions via a UML diagram and Fig. 9 show a use case of our system.

VI. CASE STUDY

The application of our distributed decision support architecture requires an infrastructure communication and simulation platforms for giving the geographically dispersed aspect of decision-makers who may interact with the system in the decision-making process. In a distributed context, where decision-makers are dispersed, the architecture of a GDSS consists of modeling a geographically dispersed structure or organization of a distributed decision support system. This allows introducing the preferences of a decision-maker via a web application, whose objective is to reproduce the behavior of a group modeled by a MAS in order to come to a collective decision about a problem. The tools used to implement our approach are:

1. *Multi Agent System:* The multi-agent platform “JADE” allows the realization of intelligent agents and to program their behaviors. It has a java interface that illustrates the decision-making process.
2. *Java Application:* uses a program (Application) in which the simulation can be run to perform the negotiation process. This application was developed with the “NetBeans” environment based on the “Java” language.
3. *User Web Interface (Decision Makers):* allows the interaction and introduction of the preferences (subjective parameters) of the decision-makers via a web page. This interface was developed by the “DREAMWEAVER” tool based on the “HTML” language.

In the following, we describe step by step the operation and progress of our approach through a case study.

The spatial group decision support system (SGDSS) proposed in this article focuses on the decision-making problem of choosing the most appropriate zone that best meets the needs of all decision-makers.

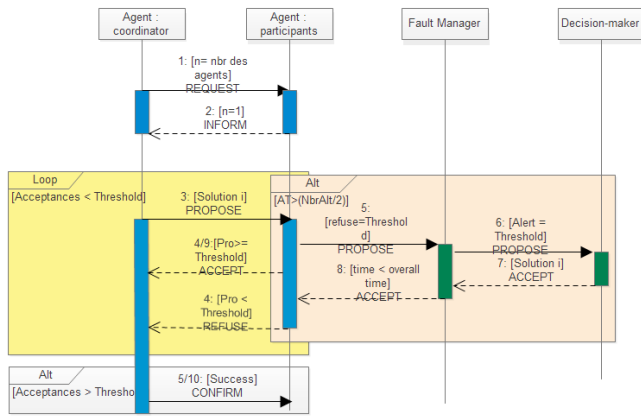

Fig. 8. Sequence diagram.

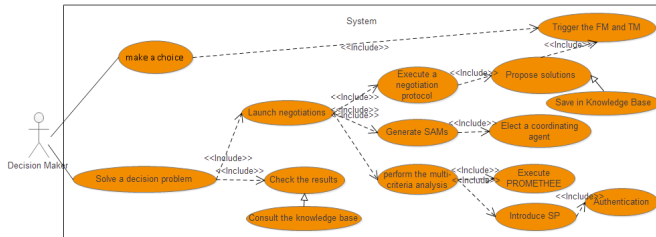

Fig. 9. Use case diagram.

As a consequence, our work is interested in the choice of a solution which satisfies most of the preferences of the decision-makers. For this reason our system is divided into two parts: Users part and Server part. The first consists of the web pages, where each decision maker has a registration window that represents his preferences, visualizations of results, and interactions. The second concerns the simulation of negotiation and processing for choosing the solution. This part is composed of several tasks, where each task is an independent treatment that will be used for negotiation thereafter.

A. The Addressed Decision Problem

For this case study, we relied on the work of Joerin [37] and taken up by Hamdadou in [23], 650 virgin ilots (alternatives) were proposed. The study area is located in the Canton of Vaud about 15 km North of Lausanne. The area of this zone is 52.500 km². Its geographical limits in the Swiss coordinating system are 532 750-532 500 (m) and 158 000-164 000 (m). In this study, we also identify the diversity of factors (environmental, social, economic, etc.). It seems wise not to aggregate all of them in a single criterion. The land relevance for habitat characteristics for this application are seven criteria, namely: damage, noise, impacts, geotechnical, natural risks, equipment, accessibility, and climate. Table V describes in detail the different criteria considered in this study.

TABLE V. DESCRIPTION OF IDENTIFIED CRITERIA

Criteria	Type	Factors
Harm	Natural	Pollution of the air and odors
Noise	Social	Highways and railways
Impacts	Social	Groundwater and sectoral
Geotechnical and natural risks	Natural	Constraints, landslides, floods, earthquakes, fires
Equipment	Economic	Distance to gas, electricity, water, roads
Accessibility	Social	Average travel time between home and work
climate	Natural	Sun, fog, temperature

The problem addressed in this case study is related to the choice of a solution (alternative) that represents a land for housing. Indeed, our work is interested on the most appropriate choice of a zone for the construction of a dwelling.

The alternatives (actions) correspond to the objects of the negotiation.

The definition and evaluation of the criteria are identified according to the different actions that generate the matrix performance. This is illustrated in Fig. 10.

N°	ID_ZONE	HARM	NOISE	IMPACTS	GEOTECH	EQUIP	ACCESS	CLIMATE
1	202	1,00	0,68	0	1	816	8	0,92
2	209	1,00	0,45	0	1	1249	9	0,91
3	210	1,00	0,69	0	1	1185	9	0,89
4	211	1,00	0,48	0	1	1518	9	0,92
5	213	1,00	0,92	0	1	1356	9	0,89
6	215	1,00	1,00	0	1	1434	8	0,75
7	216	1,00	0,97	0	1	1490	10	0,83
8	218	1,00	1,00	0	1	1556	8	0,70
9	219	1,00	1,00	0	1	1838	12	0,68
10	220	1,00	1,00	0	1	1629	8	0,68
11	221	1,00	0,95	0	1	1641	10	0,84
12	223	1,00	1,00	0	1	1697	8	0,68
13	224	1,00	0,96	0	1	1758	10	0,70
14	225	1,00	1,00	0	1	1801	8	0,67
15	226	1,00	0,91	0	1	1809	10	0,84
16	228	1,00	1,00	0	1	1840	8	0,67
17	229	1,00	0,97	0	1	1870	10	0,68
18	230	1,00	0,09	0	1	1848	12	0,55
:	:	:	:	:	:	:	:	:
:	:	:	:	:	:	:	:	:
:	:	:	:	:	:	:	:	:
:	:	:	:	:	:	:	:	:
644	9516	1,00	1,00	6	6	1568	6	0,69
645	9517	1,00	1,00	6	6	1569	8	0,67
646	9519	0,57	0,82	6	6	1589	10	0,47
647	9525	1,00	0,98	6	6	1766	12	0,07
648	9534	1,00	0,26	6	6	1912	11	0,39
649	9548	1,00	0,14	6	6	2240	12	0,66
650	9550	0,00	0,03	6	6	2012	10	0,54

Fig. 10. The performance matrix.

B. Identification of Decision-Makers

In this study, the different decision makers involved in the group decision are:

- Decision Maker 1: Environmental associations.
- Decision Maker 2: Politician.
- Decision Maker 3: Economist.
- Decision Maker 4: Public.

Each decision-maker is represented by an agent; the creation of agents is performed using the MAS JADE platform (JAVA). We attribute to each participating agent a weight in order to express his importance in the negotiation process.

C. Simulation of the Negotiation Process

1. At the User Level

Registration of the Decision Makers: they can subscribe to the web page, a password and username is assigned to each member of the group. Each decision-maker has a window that allows him to:

- Introduce the subjective parameters.
- View input data: Performance Matrix.
- Receive confirmation messages.
- Evaluate the results.

Fig. 11 and Fig. 12 show, respectively, the different functions assigned to the decision-maker in his web page.

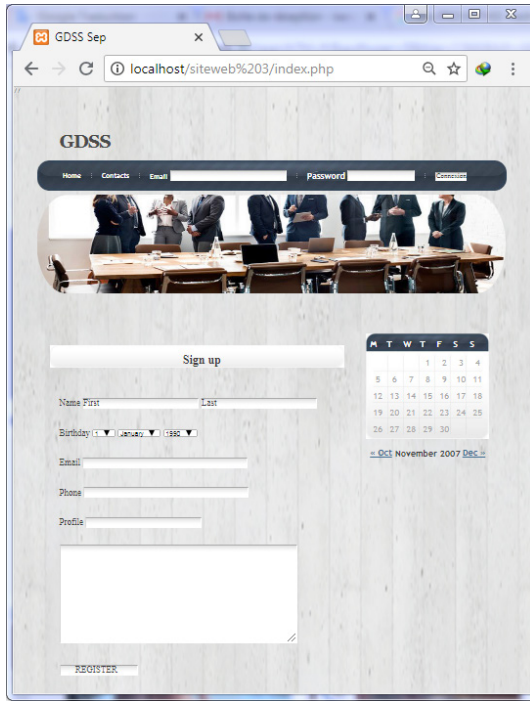

Fig. 11. Home page of a decision maker.

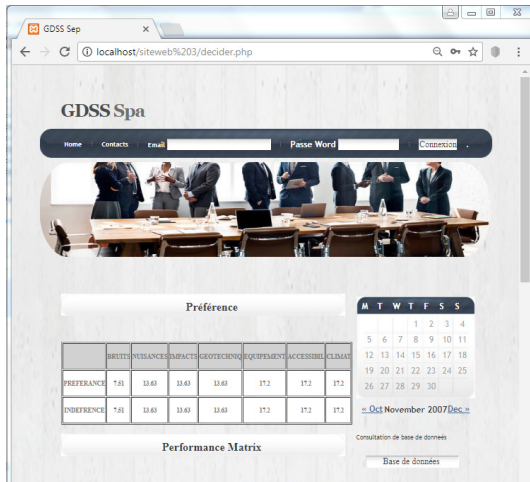

Fig. 12. Inputting subjective parameters.

performance matrix classify (Kmeans)

	Harm	Noise	impacts	Geotechnical	Equipment	Accessibility	climate	Class
1.00	0.98	0	6	2174	10	0.66	1.0	
1.00	0.73	0	6	2215	12	0.67	1.0	
1.00	1.00	2	1	1147	9	0.76	4.0	
0.96	0.58	2	1	1548	10	0.70	4.0	
1.00	1.00	2	1	1425	8	0.70	4.0	
1.00	0.99	2	1	1481	10	0.76	4.0	
1.00	1.00	2	1	1622	11	0.67	4.0	
1.00	1.00	2	1	1749	12	0.67	4.0	
1.00	1.00	2	1	1929	12	0.11	2.0	
1.00	0.99	2	1	1865	13	0.67	4.0	
1.00	0.99	2	1	1960	13	0.64	4.0	
1.00	1.00	2	1	2052	13	0.67	4.0	
1.00	0.15	2	1	2029	13	0.67	4.0	
1.00	1.00	2	1	2151	13	0.68	4.0	
1.00	0.98	2	1	2240	13	0.67	4.0	
1.00	0.48	2	1	2124	14	0.69	4.0	
1.00	0.96	2	3	736	7	0.92	4.0	
1.00	1.00	2	3	957	7	0.90	1.0	
1.00	0.63	2	3	1336	10	0.72	4.0	

Fig. 13. Clustering of alternatives by the Kmeans method.

The generation of the decision tree by a hierarchy of criteria is calculated from the clustered matrix performance. Fig. 14 shows the first level of the tree (root) that will be useful later.

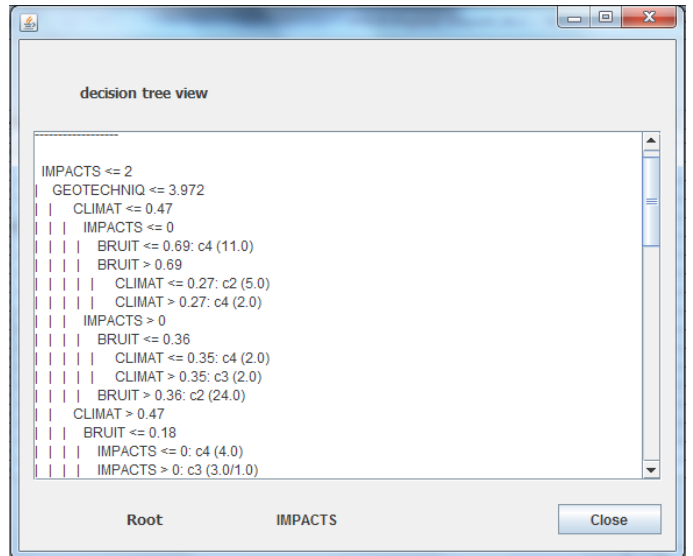

Fig. 14. Creating the decision tree using the ID3 algorithm.

2. At the Server Level

In this section, we will illustrate our proposal of the group decision support model, so beginning with the organization and creation of the necessary data for the negotiation simulation. Besides, this organization is to classify the matrix performance through using the K Means method, as shown in Fig. 13.

A set of agents is set up to reproduce the behavior of decision-makers. This latter consists of a coordinator who is elected by the system (responsible for the negotiation), and a set of participating agents.

Generating preference vectors by using PROMETHEE II (multi criteria analysis method): in Fig. 15 and Fig. 16, we show a series of experiments' illustrations that demonstrate how our system attributes subjective values and parameters to each agent involved in the group decision to begin negotiation.

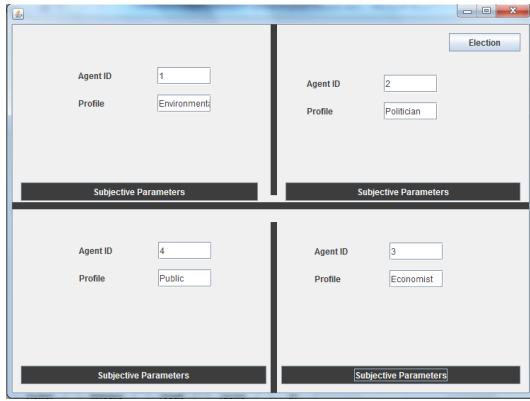

Fig. 15. Identifications of the parameters of each agent.

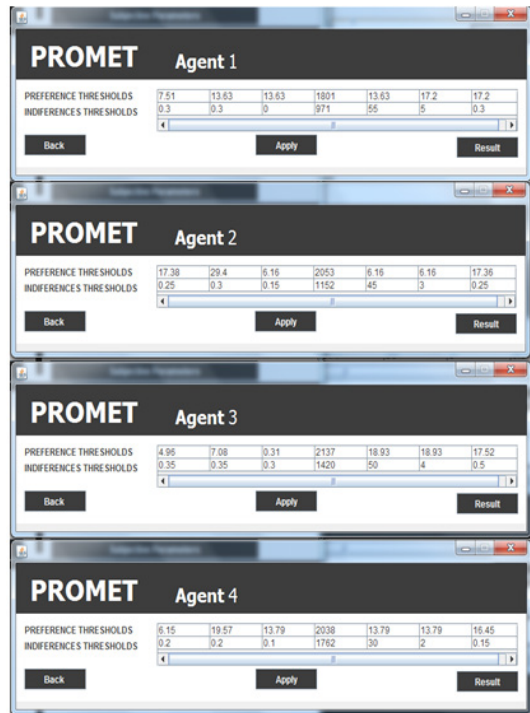

Fig. 16. Subjective parameters expressed by each decision-maker.

Loading input data: Performance matrix, subjective parameters allow calculating the ranking of alternatives (preference or ranking vector) of each decision-maker by using the PROMETHEE II method. An example of the result of this method is shown in Fig. 17.

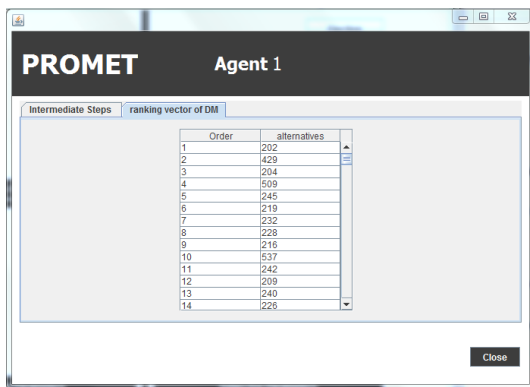

Fig. 17. Ranking calculated by the PROMETHEE II method.

The similarity process: runs to select a coordinator after generating

each decision maker ranking. Fig. 18 illustrates the ranking of alternatives (calculated from the root), and the result of the similarity process.

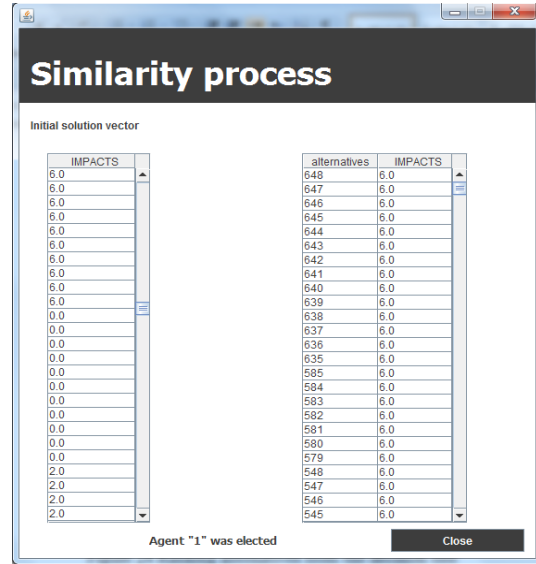

Fig. 18. Ranking alternatives from the decision tree and choosing the coordinator.

Election of the coordinator: it can be seen that agent '1' has been chosen as the coordinator shown at the bottom of the interface in Fig. 18.

Negotiation protocol: In our study, an acceptance threshold is set at (70%). If the majority accepts a proposal, it means the solution is chosen. For this purpose, the system signals the end of the negotiation and that the solution of the problem has been found. The different messages exchanged between the coordinator and the participants during the negotiation process are shown in Fig. 19 and provided by the functionality of the SMA module (the sniffer agent).

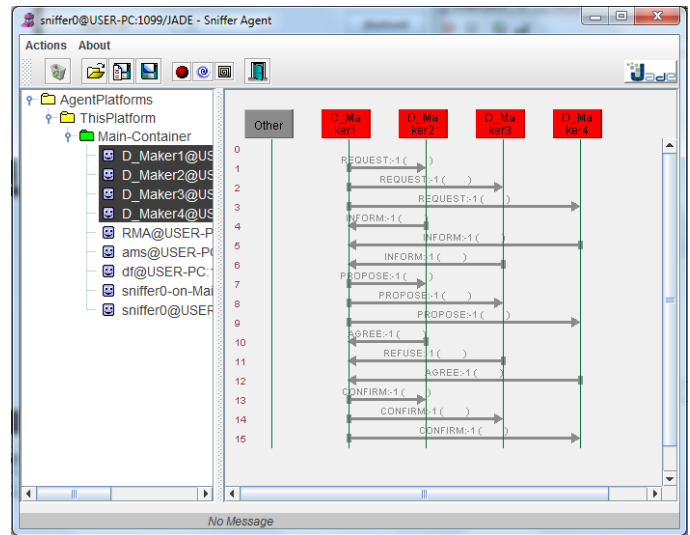

Fig. 19. The messages exchanged during the negotiation process via the sniffer.

The Group's final decision: As soon as the ultimate alternative is found, the participating agents reach a consensus. The alternative chosen is 202 as shown in Fig. 20 with a high acceptance rate. In addition, the server (system) sends the negotiation's results to the decision makers via the web interface shown in Fig. 21.

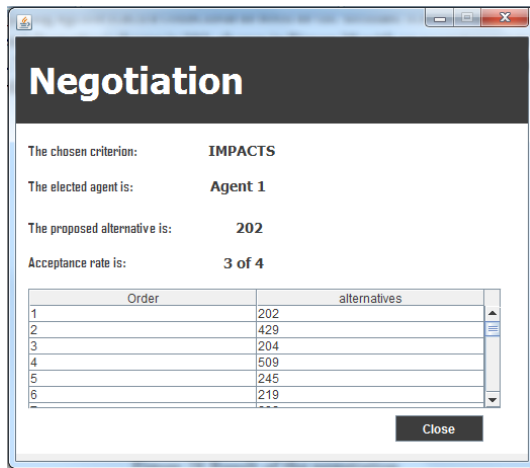

Fig. 20. Result of the negotiation.

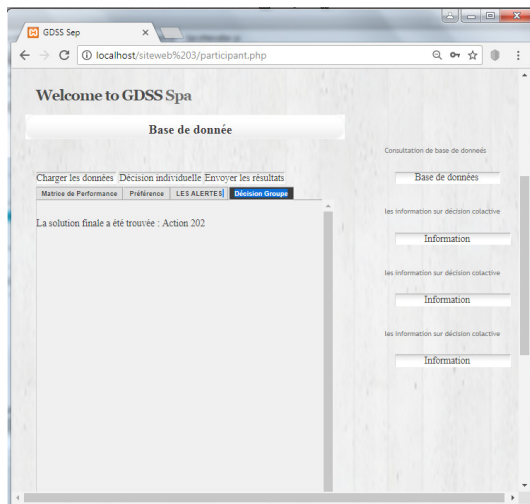

Fig. 21. Final result sent to decision-makers.

The values of the subjective parameters expressed by each decision maker are involved in the group decision and the matrix performance. Eventually, the results are stored in a database as shown in Fig. 22.

Table	Action	Lignes	Type	Interclassement	Taille	Perte
dec1p	Parcourir Structure Rechercher Insérer Vider Supprimer	3	InnoDB	latin1_swedish_ci	16,0 Kio	-
dec2p	Parcourir Structure Rechercher Insérer Vider Supprimer	3	InnoDB	latin1_swedish_ci	16,0 Kio	-
dec3p	Parcourir Structure Rechercher Insérer Vider Supprimer	3	InnoDB	latin1_swedish_ci	16,0 Kio	-
dec4p	Parcourir Structure Rechercher Insérer Vider Supprimer	3	InnoDB	latin1_swedish_ci	16,0 Kio	-
suisse	Parcourir Structure Rechercher Insérer Vider Supprimer	651	InnoDB	latin1_swedish_ci	64,0 Kio	-
wp_users	Parcourir Structure Rechercher Insérer Vider Supprimer	1	InnoDB	utf8mb4_unicode_ci	64,0 Kio	-

Fig. 22. Example of the database.

In a situation that there is not an ultimate acceptable solution according to the majority of the concerned decision-makers, the system triggers the re-election of a new coordinator. We can have a case of failure if:

- The alternatives have been exhausted.
- Re-election number is equal to the number of decision-makers (each decision-maker has become a coordinator).
- The estimated time for the negotiation is invalid (exceeding the deadline).

In this case we propose other strategies to solve this problem in order to have a deterministic protocol, such as the monotonous concession and game theory that can make the negotiation protocol more efficient.

VII. CONCLUSION AND FUTURE WORKS

In this article, we have uncovered a new research track in the field of multi-criteria decision support. We proposed a decisional group model based on a multi-agent system modeling a spatial problem.

We have developed a new approach that integrates:

- Data analysis based on a clustering method, which allows the management and manipulation of resources, in order to optimize the quality of negotiation in a spatial context.
- Multi-criteria analysis based on a multi-agent model, which reproduces the behavior of decision-makers in order to respond to the multiplicity and diversity of both the criteria and the decision-makers.

Several techniques and strategies are elaborated in this article, in order to enrich our approach which allows:

- The representation of the multiplicity of actors (decision-makers), their diversity, their behaviors and their interactions.
- The interaction of the different decision-makers facing a decision-making problem via a web application.
- The Integration of time management mechanisms during the negotiation process.
- We end this conclusion by noting the different research perspectives, which we intend to resolve in the future:
- Integration of GIS (Geographic Information System) and their functionality.
- Working on spatial data in real time.
- Development and design of a GDSS with distributed agents that operate in real time.
- Integration of other negotiation strategies between different agents.

REFERENCES

- [1] Boukherroub, T., Fondrevelle J., and GUINET, A. Multi-criteria decision making for the supply chain design: A review with emphasis on sustainable supply chains. 4th International Conference on Information Systems, Logistics and Supply Chain, ILS 2012.
- [2] Doumpos, M. and Zopounidis C. "A multicriteria decision support system for bank rating." *Decision Support Systems* 50(1): 55-63, 2010.
- [3] Natividade-Jesus, E., J. Coutinho-Rodrigues, E., and Antunes, C. "A multicriteria decision support system for housing evaluation." *Decision Support Systems* 43(3): 779-790, 2007.
- [4] Coutinho-Rodrigues, J., Simão, A, and Antunes, C. H. "A GIS-based multicriteria spatial decision support system for planning urban infrastructures." *Decision Support Systems* 51(3): 720-726, 2011.
- [5] López, J. C. L., Carrillo, P. A. Á., and Valenzuela, O. A. "A Multicriteria Group Decision Model for Ranking Technology Packages in Agriculture." *Soft Computing for Sustainability Science* 358: 137, 2017.
- [6] Yu, L. and Lai K. K. "A distance-based group decision-making methodology for multi-person multi-criteria emergency decision support." *Decision Support Systems* 51(2): 307-315, 2011.
- [7] Cao, P. P., Burstein, F., and San Pedro, J. "Extending Coordination Theory to the Field of Distributed Group Multiple Criteria Decision-Making." *Journal of Decision Systems* 13(3): 287-305, 2004.
- [8] Álvarez Carrillo, P. A., Leyva López, J. C., and Sánchez Castañeda, M. D. L. D. "An Empirical Study of the Consequences of Coordination Modes on Supporting Multicriteria Group Decision Aid Methodologies." *Journal of Decision Systems* 24(4): 383-405, 2015.
- [9] López, J. C. L., Carrillo, P. A. Á., and Chavira, D. A. G., and Noriega, J. J. S. "A web-based group decision support system for multicriteria ranking problems." *Operational Research*: 1-36, 2016.
- [10] Marjorie LE BARS. "Un Simulateur Multi-Agent pour l'Aide à la Décision d'un Collectif: Application à la Gestion d'une Ressource Limitée Agro-environnementale" thèse doctorat, UNIVERSITE PARIS IX-DAUPHINE, 2003.

- [11] Ai, W.-G., Sun, J., and Li, H. A distributed marketing decision support system based on multi-intelligent-agent. *Machine Learning and Cybernetics. Proceedings of 2004 International Conference on, IEEE*, 2004.
- [12] Hamdadou, D., Bouamrane, K. A Multicriterion SDSS for the Space Process Control: Towards a Hybrid Approach. In: Gelbukh A., Kuri Morales Á.F. (eds) MICAI 2007: Advances in Artificial Intelligence. MICAI 2007. Lecture Notes in Computer Science, vol 4827. Springer, Berlin, Heidelberg, 2007.
- [13] Zemri, F. A. and Hamdadou D. Integration of Multi Criteria Analysis Methods to a Spatio Temporal Decision Support System for Epidemiological Monitoring. *ICAASE*, 2014.
- [14] Hamdadou, D., Bouamrane, K. A Spatial Group Decision Support System: Coupling Negotiation and Multicriteria Approaches. *Intelligent Decision Technologies*, vol. 10, no. 2, pp. 129-147, 2016.
- [15] Bui, T. X. and Shakun M. F. "Negotiation processes, evolutionary systems design, and negotiator." *Group decision and negotiation* 5(4-6): 339-353, 1996.
- [16] Osborne, M. J. and Rubinstein A. *A course in game theory*, MIT press, 1994.
- [17] Lepperhoff, N. "SAM-Simulation of computer-mediated negotiations." *Journal of Artificial Societies and Social Simulation* 5(4), 2002.
- [18] Rosenschein, J. S. and G. Zlotkin. *Rules of encounter: designing conventions for automated negotiation among computers*, MIT press, 1994.
- [19] Davis, R. and Smith R. G. "Negotiation as a metaphor for distributed problem solving." *Artificial intelligence* 20(1): 63-109, 1983.
- [20] Axtell R. "Why Agents? On the Varied Motivations for Agent Computing in the Social Sciences" Santa Fe University. *Broking Institution: Center on Social and Economics Dynamics*, 22 Pp, 2000.
- [21] Duvallet, C. « Des systèmes d'aide à la décision temps réel et distribués: modélisation par agents », PHD Thesis, University of Havre, 2001.
- [22] Simos, J. *Evaluer l'impact sur l'environnement: Une approche originale par l'analyse multicritère et la négociation*. Presses polytechniques et universitaires romandes, 1990.
- [23] Hamdadou D. *Un Modèle d'Aide à la Décision en Aménagement du Territoire, une Approche Multicritère et une Approche de Négociation*, PHD Thesis, University of Oran, 2008.
- [24] ROUBA B. «Minimisation des désagréments dans les clusters agrégés », Thesis in computer science, Alger, University of Oran 1 Ahmed Benbella, 2015.
- [25] Hickey, R. and Jankowski P. "GIS and environmental decisionmaking to aid smelter reclamation planning." *Environment and Planning A* 29(1): 5-19, 1997.
- [26] Brans J.P.»Elaboration d'instruments d'aide à la décision: méthode PROMETHEE», Université Laval, Québec, p 5, 1982.
- [27] NACHET B. *Modèle multi-agents pour la conception de systèmes d'aide à la décision collective*, Thesis, University of Oran, 2014.
- [28] Lander S. E. and Lesser. V. R. "Understanding the Role of Negotiation in Distributed Search Among heterogeneous Agents" *International Joint Conference on Artificial Intelligence (IJCAI-93)*, 1993.
- [29] Sycara K. "The PERSUADER" *The Encyclopedia of Artificial Intelligence*, Shapiro J. (Eds.) New York, 1992.
- [30] Lemiere, B., Michel, P., Abriak, N. E., Haouche, L., Laboudigue, A., Alary, C. and all. "The GeDSeT project: constitution of a decision support tool (DST) for the management and material recovery of waterways sediments in Belgium and Northern France." *Déchets, Sciences et Techniques* 57: 10 p, 2010.
- [31] Taibi Boumedyen M. *L'analyse Multicritère comme outil d'aide a la décision : Application de la méthode PROMETHEE*. PHD thesis, University Abou-Bekr-Belkaid Tlemcen, 2009-2010.
- [32] McQueen, J. "Some methods for classification and analysis of multivariate observations". *Proceedings of the 5th Berkeley Symposium on Mathematical Statistics and Probability*, University of California Press, Berkeley, CA, USA, Vol.1, pp.281-297, 1967.
- [33] Candillier, L. "Contextualisation, visualisation et évaluation en apprentissage non supervisé". PHD thesis, Charles de Gaulle-Lille 3 University, 2006.
- [34] Quinlan, J. R. "Induction of decision trees." *Machine Learning* 1(1): 81-106, 1986.
- [35] Shannon, C. E. "A mathematical theory of communication." *ACM SIGMOBILE Mobile Computing and Communications Review* 5(1): 3-55, 2001.
- [36] Rakotomalala, R. «Arbres de décision.» *Revue Modulad* 33: 163-187, 2005.
- [37] Joerin.F, *Décider sur le territoire: proposition d'une approche par utilisation de SIG et de méthodes d'analyse multicritère*, PHD Thesis, University of Lausanne, 1997.
- [38] Taibi, A. and Atmani B. "Combining Fuzzy AHP with GIS and Decision Rules for Industrial Site Selection." *International Journal of Interactive Multimedia and Artificial Intelligence* 4(6) : 60-69, 2017.
- [39] Fraile, A., Larrodé, E., Magreñán, Á. A., and Sicilia, J. A. "Decision model for siting transport and logistic facilities in urban environments: A methodological approach." *Journal of Computational and Applied Mathematics* 291: 478-487, 2016.
- [40] Fraile, A., Sicilia, J. A., González, R., and González, A. "Study of Factors Affecting the Choice Modal of Transportation in an Urban Environment Using Analytic Hierarchy Process". *Workshop on Engineering Applications*, Springer, 2016.
- [41] Djamila, H. "A MultiCriteria Group Decision Support System for Industrial Diagnosis." *INFOCOMP* 10(3): 12-24, 2011.
- [42] Sicilia, J. A., Quemada, C., Royo, B., and Escuin, D. "An optimization algorithm for solving the rich vehicle routing problem based on Variable Neighborhood Search and Tabu Search metaheuristics." *Journal of Computational and Applied Mathematics* 291: 468-477, 2016.

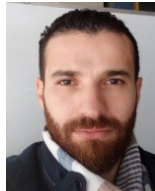

Sofiane Khiat

Sofiane khiat received his Master degree in Information System Technologies at University of Oran1 Ahmed BenBella, Algeria in 2013. Currently, he is a Ph.D. student in Computer Science Department at the same University. His research interests include Group Decision Support System, Artificial Intelligence, Multi-Agents System, Temporal Modeling and distributed systems.



Djamila Hamdadou

D. Hamdadou received her Engineering degree in Computer Science and her Master of Science degree from the Computer Science Institute in 1993 and 2000, respectively. She also obtained her doctorate in 2008. She received her PHD in 2012 from the Computer Science Department. Currently, responsible of the Research Team "Spatio Temporal Modeling and Artificial Vision: from the Sensor to the Decision" of the Laboratory of Computer Science of Oran LIO. Her research interests include Business Intelligence, Artificial Intelligence, and Spatio Temporal Modeling.